

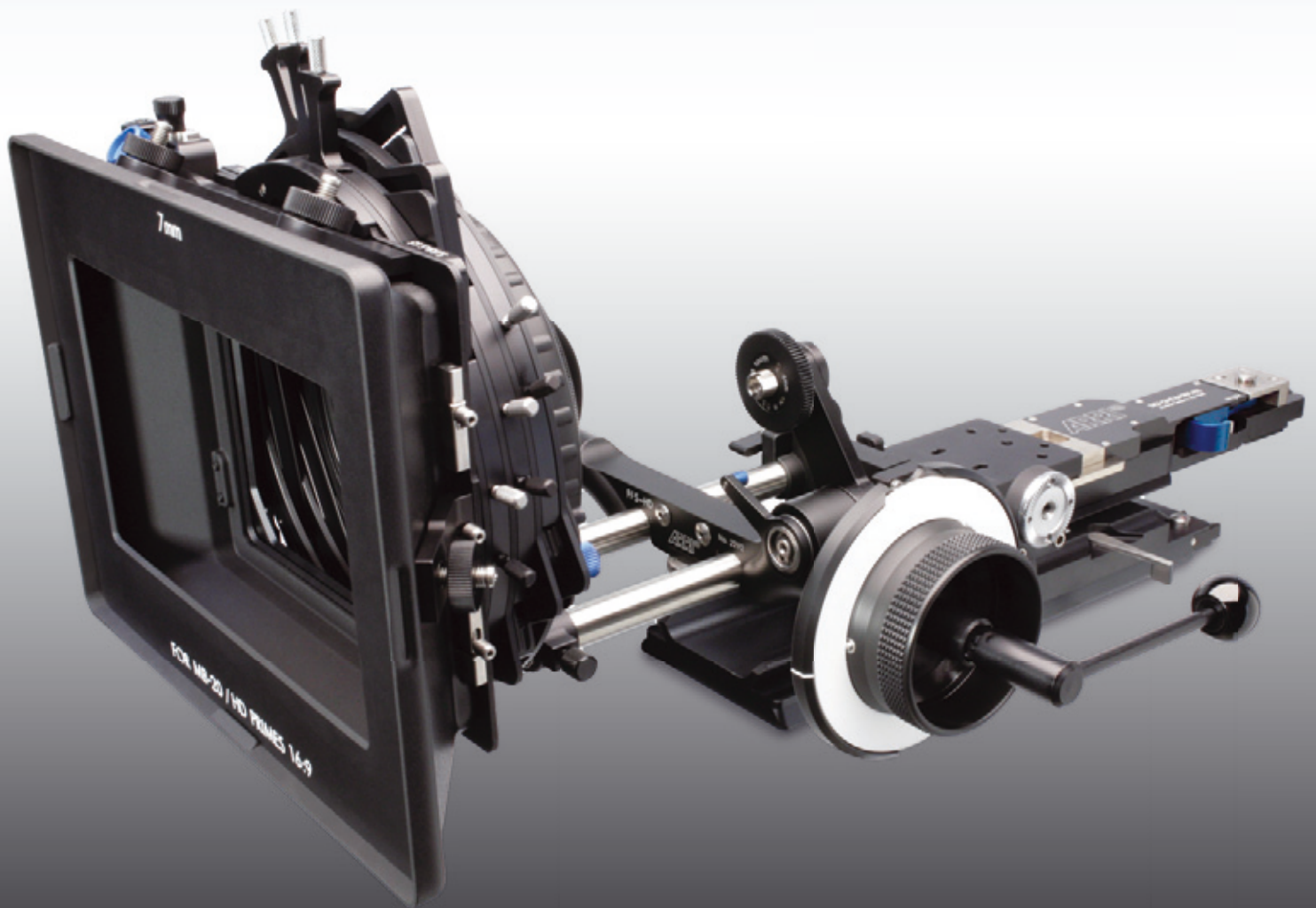

Professional Camera Accessories

ARRI Quality for Film and Digital Applications

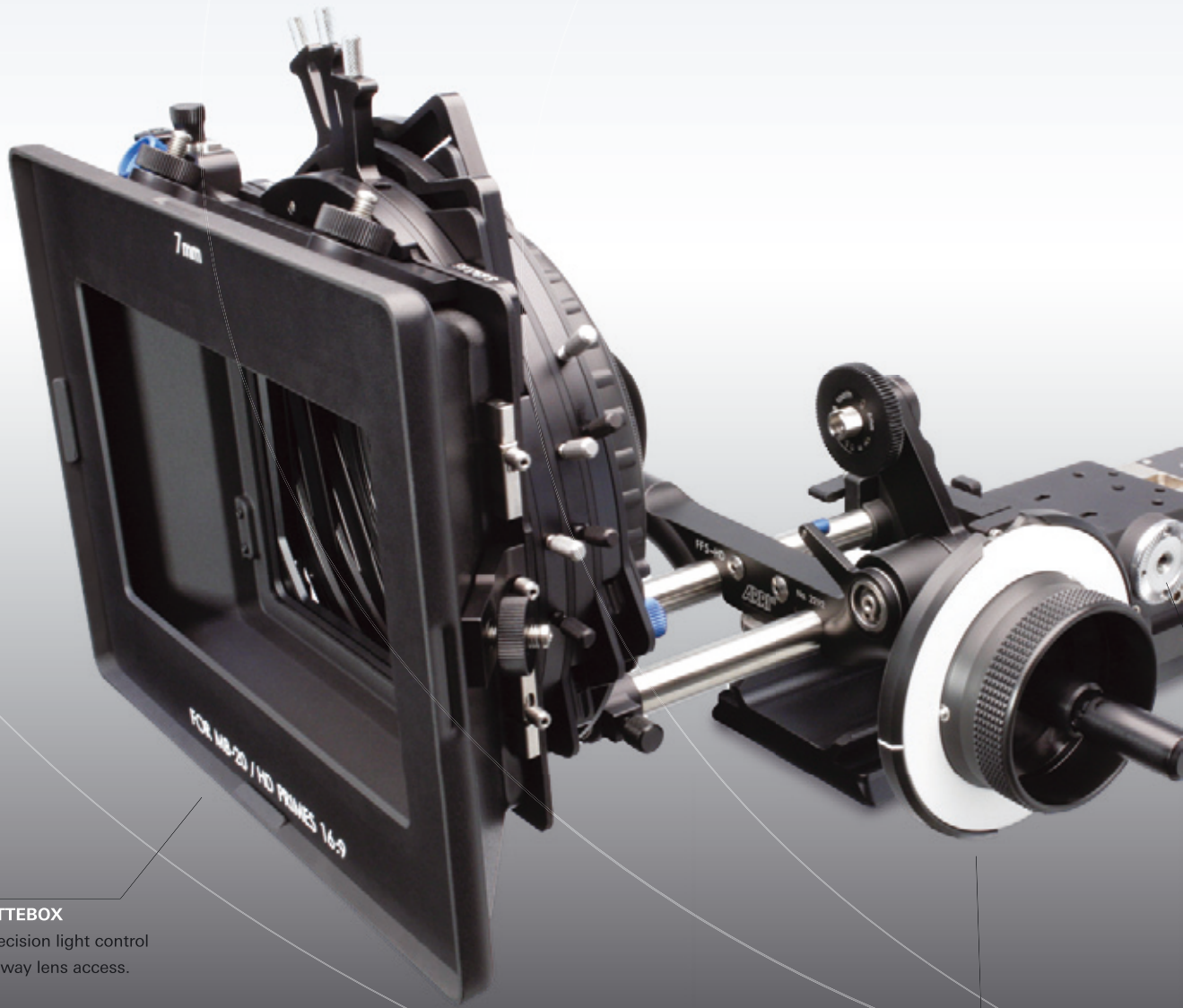



MB-20 MATTEBOX
Compact precision light control
and swing-away lens access.

FF-5 HD FOLLOW FOCUS
Modular Follow Focus System
for exacting focus pulls.

ARRI QUALITY

For Film and Digital Applications

ARRI's Professional Camera Accessories bring legendary ARRI quality, reliability and support to digital cameras. These rugged, location tested Mattebox and Follow Focus Systems have features demanded by professionals around the world. Modular construction gives you the capability to work in a wide variety of production situations, while ergonomic design makes set up and operation fast and smooth.

Modern digital production requires high quality film style accessories to help capture the striking images photographed by today's creatives. Equally at home on digital or film cameras, ARRI's new Mattebox and Follow Focus Systems provide the highest quality and unprecedented flexibility. ARRI's worldwide support means that spare parts, service and technical information are always available.

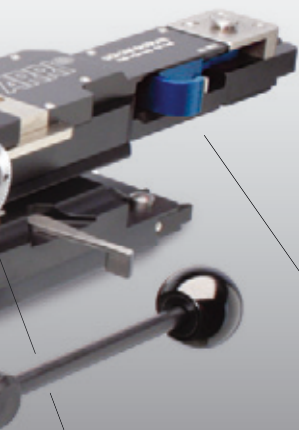

OR-HD1 QUICK RELEASE BASEPLATE

Fast changes between studio and handheld set ups with rock solid support.

ULB-3 UNIVERSAL LIGHTWEIGHT BRACKET

ARRI's on board solution for handheld shooting and accessory support.



WIRELESS REMOTE SYSTEM

Flexible, universal system for remote control of lens and camera.



MOUNTING OPTIONS

Production demands flexibility in a constantly changing shooting environment. The MB-20 Mattebox System can be used in a clamp-on mode for handheld or Steadicam shots, or mounted on a baseplate rod system for a traditional studio setup.

MB-20 Modular Compact Matte Box



The 5.65 x 5.65 Compact Mattebox easily adapts for use with lightweight support, bridgeplate support rods, or clamped on and supported by the camera lens. The swing-away Mattebox system works with wide angle lenses and provides two or three independently rotating filter stages for filter sizes up to 5.65 x 5.65. The MB-20 system includes a unique adjustment system to ensure precise fit. Optional top, bottom and side flags and masks are available for optimal light control.

ARRI's MB-20 System is the most flexible, compact mattebox available. The system accepts virtually all professional lenses including the Canon 4.7 x 11 and Fujinon 4.5 x 13, HD Primes, and all film format prime lenses as wide as 14mm. The lockable swing-away mechanism makes lenses access fast and easy.

The MB-20 System I uses a quick release removable sunshade for close-up and multiple camera work; while the MB-20 System II includes a protective cage around the sunshade for heavy duty use in demanding production environments. Both are compatible with the same support brackets, filter rings and filter trays.

Filter trays for the MB-20 system are designed to be both practical and flexible. The Combo 1 filter tray holds either a 4 x 5.65 filter horizontally or vertically and also accommodates a 5 x 5 square filter. The Combo 2 filter tray holds a 5.65 x 5.65 square filter or a 5 x 6 filter. Both filter trays feature spring-loaded holders to make filter handling fast and simple.

THE MB-20 SYSTEM FEATURES

- Designed for film and digital cameras
- Works with wide angle HD zooms
- Modular construction allows all mounting options
- Offers up to three independently rotating filter stages
- Accommodates a wide range of filter sizes
- All filters can be individually rotated and locked off
- Can be equipped with top, bottom, side flags and masks
- Provides an upgrade path as wider HD lenses come to market
- Locking swing-away lens access

MB-20 System II Modular Compact Matte Box

Like the MB-20, the MB-20 System II is a compact matte box designed to accommodate even wide angle lenses like the Fujinon 4.5 13, while still being light-weight enough to be used hand held. ARRI's new and innovative patent-pending cage design allows for use of videography-style light shields without sacrificing durability, and gives full protection of the sunshade against shocks.

The new patent-pending cage



MB-20 II Super Wide 16x9 Module Modular Compact Matte Box 16x9



The MB-20 System II Super Wide 16 x 9 Module is a sunshade, carrier and filter stage primarily intended for use with 4 x 5.65 filters. When used in HDTV format, it is compatible with lenses as wide as 3.9mm.

The MB-20 System II accepts MB-20 support brackets and filter rings, improving convenience and utilization for multiple camera owners.

The MB-20 Concept – Modular, Functional And Flexible



By adopting a functional, modular approach, the ARRI MB-20 accommodates most modern lenses and standard filter formats. Whether the script calls for a traditional studio setup, handheld move or Steadicam shot, the ARRI MB-20 system adapts to each scenario without a hitch.

LMB-15 Lightweight Mattebox



The ARRI LMB-15 is the perfect choice for those requiring a lightweight clamp-on mattebox solution. The 4 x 5.65 horizontally oriented filter trays slide into heavy duty machined guides with ease. The LMB-15 can be rapidly configured for two or three stage capacity.

The LMB-15 is compatible with LMB-5 filter trays, clamp adapter backs and carbon fiber light shields. For greater flexibility, the new 130mm back also works with clamp-on rings from the MB-20 system. The LMB-15 accepts ENG lenses as wide as 3.9mm and has a quick release removable sunshade for close-up applications.

FF5-HD

Modular Follow Focus



With the ARRI Follow Focus FF5-HD, a completely modular, film style follow focus is now available for digital productions. Designed specifically for lenses with a smaller diameter focus barrel, the FF-5's longer swing arm ensures proper gear position on the focus ring and a lower gear ratio for a more exacting focus pull on smaller diameter lenses or those with compressed focus scales.

The FF5-HD integral snap-on mechanism locks to 15mm lightweight support rods and can be adapted to work with ARRI standard 15mm or 19mm bridge-plate support rods. ARRI Follow Focus drive gears can be attached to either side of the swing arm, allowing greater mounting flexibility.

ARRI gears are made from low friction Delrin for optimal drive smoothness and use precise self-centering stainless steel couplings to eliminate runout and wear.

For more options, the FF-5HD is compatible with all ARRI FF-4 Follow Focus accessories. Right and left focus knobs and the FF-5's longer body allow operation from either camera side with ENG lenses.

In addition, an extension is available to clear the largest matteboxes. Short and long focus whips allow the assistant to stand farther away from the camera and a focus crank makes fast snap zooms smooth and accurate.



There is no need to compromise when focus is critical or complex. The ARRI FF-5HD follow focus system brings film style quality and precision to digital production, giving digital cinematographers the control necessary to get the shot the first time, every time.



Adapters to work with ARRI standard bridgeplate 15mm and 19mm rods.

ULB-3 Universal Lightweight Bracket

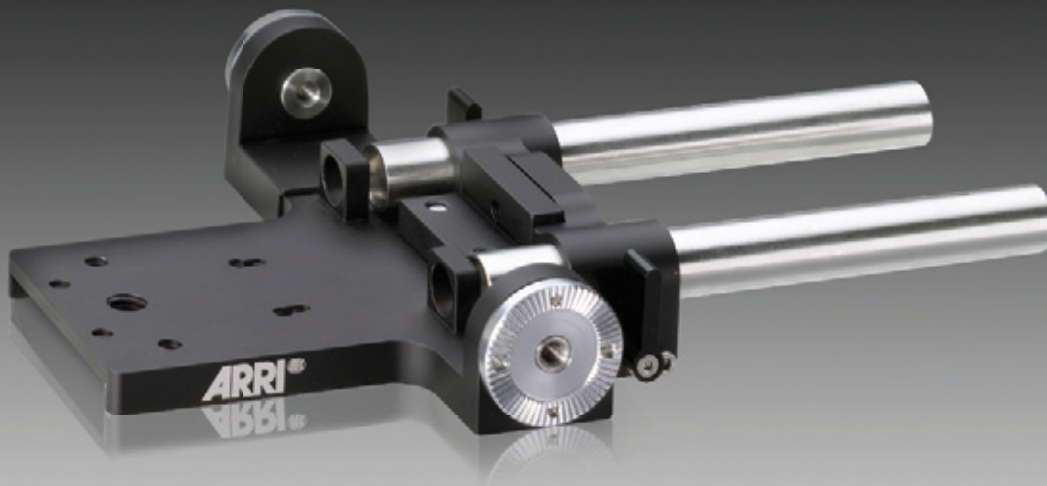

The ULB-3, specifically designed for digital cinematography, replaces the stock v-shoe attachment common on cameras such as the Sony F900, Panasonic Varicam and HDX 900.*

A universal drill pattern allows direct mounting to the camera body and new dial support post attachments provide additional stability and reduce flex.

This unit incorporates a right side rosette for handgrip attachment with optional left rosette for two-handed operation.

As with the QR-HD1, the ULB-3 incorporates a centering adjustment system to compensate for variations in camera base to optical axis measurement.

*For compatibility with other cameras please contact your ARRI representative.

QR-HD1 Quick Release HD Baseplate

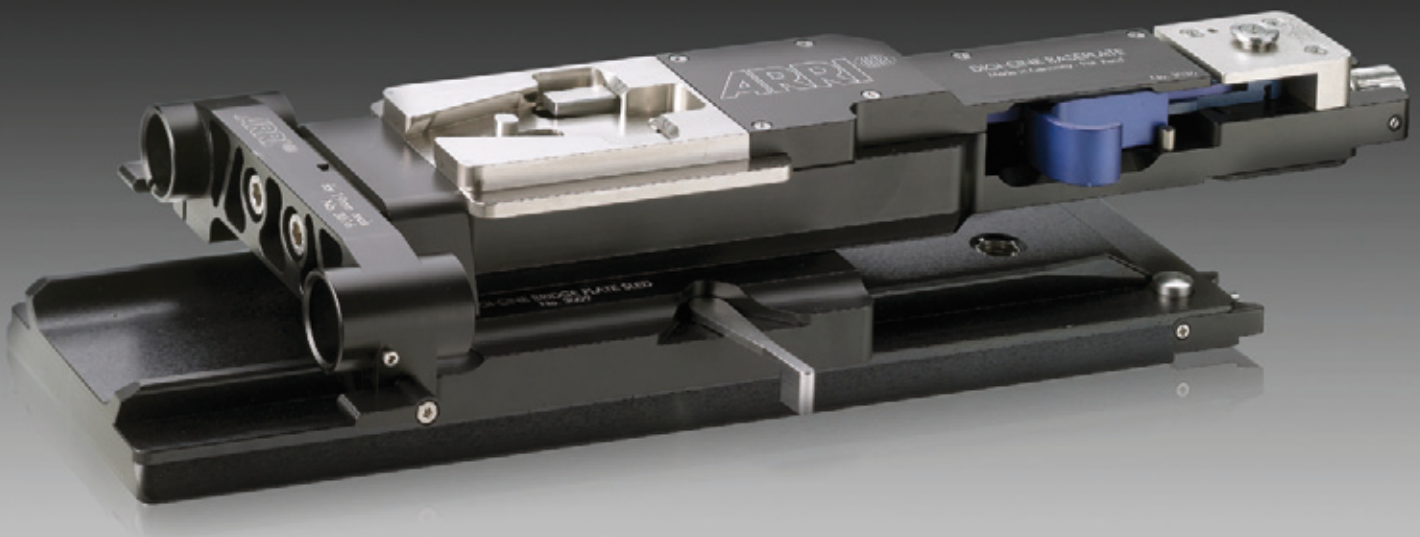

The need to change between studio and handheld configurations is a common production problem and the quick release mechanism in ARRI's QR-HD1 makes transitions fast and easy. The bridgeplate adapts to either ARRI Standard 19mm rod size or the popular ARRI 15mm rods.

The Quick Release Baseplate's unique attachment mechanism provides rock-solid camera support with a centering adjustment that compensates for variations in camera base to optical axis measurements. Full compatibility with cameras such as the Panasonic Varicam, Sony F950 and Sony HDC-1500 is thus assured.

The dedicated baseplate rod holder has a unique centering system, adjustable both vertically and horizontally. The rear clamp collar post is adjustable from 1.5mm to 2mm, ensuring a solid attachment.

The QR-HD1 features a mechanically locked camera base to bridgeplate attachment which can be adjusted for a perfect fit via a knurled knob on the rear of the unit. This system provides a more solid attachment than the common spring-tensioned systems.

Note: The Sony F23 and RED One are not V-Lock cameras. The F23 is fully compatible with ARRIFLEX cine bridgeplates BP-3, BP-5, BP-8 and BP-9. The RED One uses a proprietary support system (available from RED) that fully conforms to the ARRI support rod standard.



In addition the ZMU-3 can be wired directly to a single lens motor or it can be wired to the UMC-3 when multiple lens motors are used. To top it off, the ZMU-3 can also be connected directly to various video zoom lenses to control their integrated zoom motors.



WRS Wireless Remote System

The ARRI Wireless Remote System (WRS), the premiere means for wirelessly controlling lens and camera on the film set, is now also available to video productions. New software and a selection of cables allow the smallest and most flexible remote system on the market to interface with video cameras.

The WRS is a modular system, so its components can be configured in a multitude of ways to suit any kind of shooting situation, from simple one axis follow focus shots to complex multicamera shoots. To assure robust transmission, ease of use and greater flexibility.

The CLM-2 motors drive the lens, while the UMC-3 module mounts to the camera and communicates with the small and ergonomic hand units for focus, iris and zoom control.





The Wireless Remote System is fully compatible with both cine-style and ENG lenses.



Handheld Control-Units

Wireless Remote System



UMC-3 Universal Motor Controller



The UMC-3 contains lens motor electronics for up to three motors and the radio that communicates with the hand unit. The UMC-3 can connect to selected video cameras to start recording, and it can connect to selected video lenses to control them directly.

WMU-3 Wireless Main Unit



The WMU-3 is held in the assistant's hand. It communicates with the UMC-3 on the camera and accepts the hand controllers for focus, zoom and iris. Through the clean and elegant geometry of the modular hand units the system can be used equally well in the left or right hand.

WFU-3 Wireless Focus Unit



The WFU-3 is used to control focus and/or iris. Focus and iris can be assigned freely to hand wheel and slider, and electronic lens and knob limits can be easily set. In addition it is possible to set mechanical knob limits. The movable index marker is especially useful when the WFU-3 is held at different angles or swapped between hands.

ZMU-3 Zoom Main Unit



The ZMU-3 is an ergonomically shaped zoom controller that can be used in three different configurations, providing maximum flexibility. Zoom speed can be precisely adjusted and zoom limits can be set. A large bar graph shows the zoom ring position, zoom speed and various status messages. The ZAP button allows for a quick focus check. With the rosette on the right side of the ZMU-3 it can be attached to a tripod handle.

Other Compatible Accessories

Matte Boxes and Follow Focus

The ARRI Professional Camera Accessories program also includes many well-known accessory items that can be used on all film and digital cameras with the appropriate support system:

MB-14 Studio Matte Box



- Maximum filter size 6.6"x6.6" / round 6"
- Full-feature studio matte box for all lenses out to super-wides, including large 35mm and HD zooms.
- Requires studio bridge plate or ARRI HD baseplate.

MB-16 Production Matte Box



- Filter size 4"x4" / round 4.5"
- Compact matte box for medium focal-length primes, 16mm and HD zooms.
- Requires studio bridge plate or ARRI HD baseplate.

FF-4 Studio Follow Focus



- Complete follow focus system for use with film and cine-style lenses. Gear ratio is appropriate for lens barrels having large angular range.
- Compatible with focus knobs from FF5-HD and all ARRI driver gears.
- Compatible with ARRI lightweight support.
- With adapter, compatible with studio bridge plate and ARRI HD baseplate.



MB-18 Compact Studio Matte Box



- Filter size 4"x5.65" / round 138mm
- Flexible mattebox offering coverage for wider primes and some zooms.
- Requires studio bridge plate or ARRI HD baseplate.

MB-19 Production Matte Box



- Filter size 4"x5.65" / round 138mm
- Compact lightweight matte box for medium-wide primes, 16mm and HD zooms.
- Compatible with ARRI lightweight support.
- With adapter, compatible with studio bridge plate and ARRI HD baseplate.

LFF-1 Lightweight Follow Focus



- Compact follow-focus unit for handheld and rig applications.
- Extremely low internal backlash.
- Focus knobs have zero-backlash couplings.
- Compatible with all ARRI driver gears.
- Flexible attachment mount for use with one support rod.

CONFIGURATION OVERVIEW

Quick Release HD Base Plate

Quick Release HD Baseplate

- Quick switch from tripod to hand held for video cameras
- Compatible with ARRI studio rod system
- Unique centering adjustment allows perfect fit with many video cameras

Quick Release HD Baseplate Set 19mm,
including complement of rods
Set includes:
- Quick Release HD Baseplate
- Bridge Plate Sled with Bottom Dovetail Plate
- 19mm Support Rod Holder
- 240, 340 and 440mm Rods (19mm)
K0.60053.0

Quick Release HD Baseplate Set 19mm,
Set includes:
- Quick Release HD Baseplate
- Bridge Plate Sled with Bottom Dovetail Plate
- 19mm Support Rod Holder
Support Rods must be ordered seperately!
K0.60050.0

Quick Release HD Baseplate Set 15mm,
including complement of rods
Set includes:
- Quick Release HD Baseplate
- Bridge Plate Sled with Bottom Dovetail Plate
- 15mm Support Rod Holder
- 240, 340 and 440mm Rods (15mm)
K0.60054.0

Quick Release HD Baseplate Set 15mm,
Set includes:
- Quick Release HD Baseplate
- Bridge Plate Sled with Bottom Dovetail Plate
- 15mm Support Rod Holder
Support Rods must be ordered seperately!
K0.60051.0

Quick Release HD Baseplate Set

- All sets include:**
- Quick Release HD Baseplate
 - Bridge Plate Sled
 - Bottom Dovetail Plate
 - Support Rod Holder (size see set specification)
 - Rods (size see set specification)



Adapter Plates for 19mm and 15mm Studio Rods and Studio Accessories

THOMSON VIDEO CAMERAS



PANASONIC VIDEO CAMERAS



SONY VIDEO CAMERAS



Quick Release HD Baseplate

Tripod

Most flexible connection of camera to tripod

THOMSON VIDEO CAMERAS



PANASONIC VIDEO CAMERAS



Sony/Thomson adapter plate
SAP-3,
K2.47641.0

Panasonic adapter plate
PAP-2,
K2.47645.0



Tripod

Adapter plate is attached to Bridge Plate

Digital Support Accessories

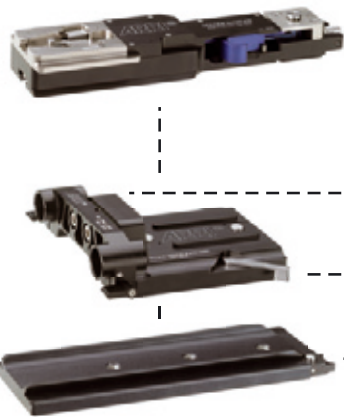

Quick Release HD Baseplate
K2.47796.0

Support Rod Holder 19mm, K2.47798.0
Support Rod Holder 15mm, K2.47799.0

Bridge Plate Sled
(does not include Support Rod Holder)
K2.47797.0

Bottom Dove Tail Plate
K4.54362.0

19mm Studio Rods



440mm, K5.42904.0



340mm, K4.47347.

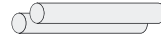

240mm, K2.43046.0

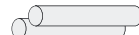

Lightweight rod set 185mm
K2.55024.0

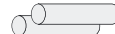

Lightweight rod set 165mm
K2.55023.0

15mm Studio Rods



440mm, K5.21957.0



340mm, K4.47348.0



240mm, K2.21958.0

15mm Support rods with threads for LWS-3 (pairs)

5mm, K2.47111.0, **27mm**, K2.47112.0
113mm, K2.47114.0, **126mm**, K2.47113.0

Lens Support



Lens Support LS-9
for 19mm rods
K2.47227.0



Lens Support LS-10
for 15mm rods
K2.47228.0

Adapter Plate for Lightweight Support System

SONY VIDEO CAMERAS



Sony adapter plate SAP-3,
K2.47641.0

Bridge Plate for 16SR
19mm rods: **BP-6**, K2.42572.0
15mm rods: **BP-7**, K2.41010.0
(one pair of 340mm rods included)

THOMSON VIDEO CAMERAS



PANASONIC VIDEO CAMERAS



SONY VIDEO CAMERAS



Universal Lightweight Support ULB-3, K2.47650.0



Digital Camera Hand Grip Adapter Cable
K2.47649.0



Handgrip Extension
K2.47648.0



Camera Handgrip Right
K2.45886.0

Extension tube for handgrip
K2.47136.0

with a screw

CONFIGURATION OVERVIEW

Control Accessories



Wireless Main Unit
WMU-3, K2.52240.0

Antenna, 05.20112.0



Wireless Focus Unit
WFU-3, K2.52268.0

Marking Disks
Bevelled, K4.47621.0
Flat, K2.47292.0



Wireless Zoom Unit
WZU-3, K2.52267.0



Wireless Remote Control
WRC-1, K2.52087.0



Lens Data
LDD-FP,

Electronic Accessories



Wireless Battery Unit
WBU-3, K2.52238.0



Wireless Battery Unit
WBU-4, K2.65001.0



Wireless Accu Charger
WAC-3, K2.52266.0



Wired Handgrip Attachment
WHA-3, K2.54079.0



Controlled Lens Motor CLM-2
K2.52036.0



Controlled Lens
K2.41378.0

Mechanical Accessories



Wireless Expansion Bracket
WEB-3, K2.52241.0



Wireless Zoom Bracket
WZB-3, K2.65017.0



MB Bracket for LDD-FP
MB 14/15, K2.54166.0
MB 16/18, K2.54167.0
MB 19/20, K2.54168.0



WHA-2 Rod Bracket
K2.52150.0



WHA-2 Rosette Bracket
K2.52153.0



Quick Change
UMC 3/8",

Sample Configurations



WBU-3, WMU-3, WZU-3, WFU-3



WBU-3, WMU-3, WRC-1,
WEB-3, WFU-3



WBU-3, WMU-3, WFU-3,
WEB-3, LDD-FP



WBU-3, WMU-3,
LDD-FP, WEB-3,
WFU-3, ZMU-3, WZB-3

Wireless Remote System

Receivers & Motor Controllers



Display for Focus Puller
K2.54163.0



Zoom Main Unit
ZMU-3, K2.65003.0

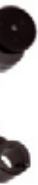

Motor CLM-1



LDD-FP Update Cable
K2.65011.0

WMU-3 Update Cable
KC 87-S K2.52270.0

WRC Update Cable
KC 84. K2.55849.0



Cine Tape Measure



Adapter
K2.52080.0



3/8" Accessory Shoe
K2.54077.0



3/8" Accessory
Shoe Expander
K2.54030.0



Console CLM-2
K2.52035.0



Studio Lens Data Box



ARRICAM STUDIO



Lite Lens Data Box



ARRICAM LITE



FEM-2 + URM-3



435 Xtreme/Advanced



UMC-3



all other cameras including
235, 535, 16SR3
also: ENG Cameras



UMC-1 & URM-2/3

Wired Configurations



Antenna Cable 15m
WC-A3, K2.52263.0

Example:

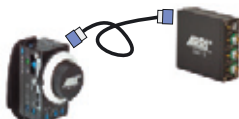

WMU-3 to UMC-3 via
Antenna Cable WC-A3



LCS Cable
LC-Z1 (3,5m/11ft) K4.41395.0
LC-Z2 (7m/23ft) K2.41396.0



LCS Cable (coiled)
LC-M1 (1m/3ft) K4.41397.0
LC-M2 (2m/6ft) K2.43871.0



Cable Drum 75m/250ft
LC-E1, K2.41389.0

Example:



WFU-3 on WHA-3 via WHA-2 LCS Cable to Studio LDB



WHA-2 CAC Cable 3m/9ft
KC 70, K2.54135.0

Example:



WFU-3 on WHA-3 via WHA-2 CAC Cable
to ARRICAM Studio CAC Connector

CONFIGURATION OVERVIEW

VIDEO Lenses

HDTV Lenses

Angenieux HDTV		
10x5,3	∅ 92 mm	VA92
11,5x5,3*	∅ 100 mm	VB100, Z
12x9,7	∅ 162 mm	--

Canon HDTV		
FJ 9mm Prime	∅ 80 mm	VA80
FJ 14mm Prime	∅ 80 mm	VA80
FJ 24mm Prime	∅ 80 mm	VA80
FJ 35mm Prime	∅ 80 mm	VA80
HJ 16x8	∅ 85 mm	VA85
HJ 9x5,5	∅ 86 mm	VA86
HJ 9x5,5 KLL-SC*	∅ 86 mm	VA86
HJ 11x4,7	∅ 95 mm	VA95
HJ 11x4,7 KLL-SC*	∅ 95 mm	VA95
HJ 15x8	∅ 98 mm	VB98
HJ 20x8	∅ 98 mm	VB98
HJ 21x7,8	∅ 98 mm	VB98
HJ 18x7,8	∅ 105 mm	***
HJ 18x7,8 KLL-SC*	∅ 105 mm	***
HJ 21x7,5	∅ 117 mm	***
FJ 5mm Prime	∅ 120 mm	***
HJ 21x7,5 KLL-SC*	∅ 130 mm	***
HJ 40x10	∅ 132 mm	***
HJ 40x14	∅ 132 mm	***

Cooke HDTV		
8-46mm Zoom A*)	∅ 150 mm	***

Fujinon HDTV		
HA 10x5	∅ 85 mm	***
HA 10x5 B-10*	∅ 85 mm	VA85
HA 17x7,8	∅ 85 mm	VA85
HA 17x7,8 B-10*	∅ 85 mm	VA85
HA 10x5,2	∅ 95 mm	VA95, C, T
HA 13x4,5	∅ 95 mm	VA95
HA 13x4,5 B-10*	∅ 95 mm	VA95
HA 5mm Prime (new)	∅ 95 mm	C, T
HA 8mm Prime	∅ 95 mm	C, T
HA 12mm Prime	∅ 95 mm	C, T
HA 16mm Prime	∅ 95 mm	C, T
HA 20mm Prime	∅ 95 mm	C, T
HA 34mm Prime	∅ 95 mm	C, T
HA 40mm Prime	∅ 95 mm	C, T
HA 40mm Prime B-M10*	∅ 95 mm	C, T
HA 54mm Prime	∅ 95 mm	C, T
HA 54mm Prime B-M10*	∅ 95 mm	C, T
HA 14x8	∅ 96 mm	VB96
HA 15x8	∅ 100 mm	VB100, Z
HA 22x7,8	∅ 100 mm	VB100, Z
HAc 15x7,3 B-10*	∅ 110 mm	VB110, K, W
HA 20x7,5	∅ 110 mm	VB110, K, W
HA 20x7,8	∅ 110 mm	VB110, K, W
HA 20x7,8 B-10*	∅ 110 mm	VB110, K, W
HA 22x7,3	∅ 110 mm	VB110, K, W
HA 5mm Prime (old)	∅ 120 mm	***
Hae 3x5 B-10*	∅ 128 mm	***
HA 5x6 B-10*	∅ 128 mm	***
HAE 10x10 B-10*	∅ 128 mm	***
HA 36x10,5	∅ 130 mm	***
HA 42x9,7	∅ 130 mm	***
HA 12x9,5 B-10*	∅ 156 mm	***

2/3" Lenses

Angenieux 2/3"		
15x8,3	∅ 85 mm	VA85
14x9	∅ 92 mm	VA92
12x5,3	∅ 92 mm	VA92
26x7,8	∅ 103 mm	--

Canon 2/3"		
J 13a x9	∅ 80 mm	VA80
J 15 x 9,5	∅ 80 mm	VA80
J 14x8	∅ 85 mm	VA85
J 15a x8	∅ 85 mm	VA85
J 16a x 8	∅ 85 mm	VA85
J 17a x7,7	∅ 85 mm	VA85
YJ 17x9,5	∅ 85 mm	VA85
YJ 18x9	∅ 85 mm	VA85
YJ 19x9	∅ 85 mm	VA85
J 9a x5,2	∅ 86 mm	VA86
YJ 12x6,5	∅ 86 mm	VA86
J 18,8,5	∅ 90 mm	VA90
J 8x6	∅ 95 mm	C, T
J 9a x5,2 KLL-SC*	∅ 95 mm	C, T
J 11x4,5	∅ 95 mm	VA95
J 20a x 8	∅ 98 mm	VB98
J 21a x7,8	∅ 98 mm	VB98
J 33a x11	∅ 130 mm	***
J 33a x15	∅ 130 mm	***

Fujinon 2/3"		
A14x8,5	∅ 80 mm	VA80
A14x9	∅ 80 mm	VA80
A16x9	∅ 80 mm	VA80
A16x9,5	∅ 80 mm	VA80
A13x6,3	∅ 85 mm	VA85
A15x8	∅ 85 mm	VA85
A17x9	∅ 85 mm	VA85
A17x7,8	∅ 85 mm	VA85
A19x8,7	∅ 85 mm	VA85
A20x8,6	∅ 85 mm	VA85
A18*8,5	∅ 90 mm	VA90
A10x4,8	∅ 95 mm	VA95
A10x4,8 (B-M0)	∅ 95 mm	VA95
A13x4,5	∅ 95 mm	VA95
A13x4,5	∅ 95 mm	VA95
A8,5x5,5	∅ 100 mm	VB100, Z
A12*6,8	∅ 100 mm	VB100, Z
A14x8	∅ 100 mm	VB100, Z
A20x8	∅ 100 mm	VB100, Z
A22x7,8	∅ 100 mm	VB100, Z
A22x12,5	∅ 110 mm	VB110, K, W
A24x11,5	∅ 110 mm	VB110, K, W
A24x16,5	∅ 110 mm	VB110, K, W
A36x10,5	∅ 130 mm	***
A36x14,5	∅ 130 mm	***

Zeiss HDTV		
3.9mm Digi Prime	∅ 117 mm	
5-70mm Digi Primes	∅ 95 mm	C, T
6-24mm DigiZoom	∅ 95 mm	C, T

1/2" Lenses

Canon 1/2"		
PH 13a x7	∅ 80 mm	VA80
PH 15x7 Type 1	∅ 80 mm	VA80
YH 13x7,5	∅ 85 mm	VA85
PH 14a x6,6	∅ 85 mm	VA85
H 15a x6	∅ 85 mm	VA85
PH 15x7 Type 2	∅ 85 mm	VA85
YH 17x7	∅ 85 mm	VA85
YH 18x6,7	∅ 85 mm	VA85
YH 19x6,7	∅ 85 mm	VA85
YH 12x4,8	∅ 86 mm	VA86
PH 18x6,2	∅ 90 mm	VA90
H 20a x6	∅ 98 mm	VB98
H 21a x5,8	∅ 98 mm	VB98

Fujinon 1/2"		
S14x7,3	∅ 65 mm	--
S14x6,4	∅ 80 mm	VA80
S14x6,6	∅ 80 mm	VA80
S16x6,7	∅ 80 mm	VA80
S16x7	∅ 80 mm	VA80
S12x5	∅ 85 mm	VA85
S13x4,6	∅ 85 mm	VA85
S15x6,1	∅ 85 mm	VA85
S17x6,6	∅ 85 mm	VA85
S19*6,5	∅ 85 mm	VA85
S20x6,4	∅ 85 mm	VA85
S8,5x4,2	∅ 100 mm	VB100, Z
S14x6,2	∅ 100 mm	VB100, Z
S18x6,4	∅ 100 mm	VB100, Z
S18x6,6	∅ 100 mm	VB100, Z
S22x5,8	∅ 100 mm	VB100, Z

Gear Modules		
Lens	Rings	Module
Angenieux 2/3"	Focus, Iris, Zoom	0,5
Canon 2/3"	Focus, Iris, Zoom	0,5
Fujinon 2/3"	Iris	0,4
Fujinon 2/3"	Focus, Zoom	0,6
Cine Style	Focus, Iris, Zoom	0,8

A*) cine style lens gears are 0,8 module

Lens Diameter Table

Cine Lenses

focal length	lens front diameter	MB-14	MB-16	MB-18	MB-19	MB-20	LMB-3	LMB-4	LMB-4A	LMB-5
ARRI/ZEISS Master Prime										
16 mm	∅ 114	D, H, U	n. r.**	D, H, U	n. r.**	D, H, U	--	--	--	D
all other Master Primes	∅ 114	D, H, U	D, H, U	D, H, U	D, H, U	D, H, U	--	--	--	D
ARRI/Zeiss LDS Ultra Prime										
12 mm	∅ 156	MB-14-W	--	--	--	--	--	P2	P2	--
14 mm	∅ 114	D, H, U	--	D, H, U	D, H, U	D, H, U	--	--	--	D
Primes 16-180 mm	∅ 104	I, V	I, V	I, V	I, V	I, V	--	--	--	I, V
ARRI/Zeiss Standards (T2.1)										
10 mm	∅ 156	P*	--	--	--	--	--	P2	P2	--
12 mm	∅ 135	L	--	--	--	--	--	c.s.***	c.s.***	--
14 mm	∅ 114	D, H, U	--	D, H, U	D, H, U	D, H, U	--	--	--	D
Primes 16-180 mm	∅ 80	A, S	A, S	A, S	A, S	A, S	A, S	--	--	A, S
300 mm	∅ 125	G, X, Y	G, X, Y	X, Y	X, Y	X, Y	--	--	--	--
ARRI/Zeiss Zoom										
10-100 mm	∅ 87	B, R	B, R	B, R	B, R	B, R	B	--	--	B
11-110 mm	∅ 87	B, R	B, R	B, R	B, R	B, R	B	--	--	B
VP 1, 2, 3	∅ 150	O, Q	--	--	--	--	--	--	--	--
ARRI Shift & Tilt ****										
18 mm	∅ 95	C, T	C, T	C, T	C, T	C, T	--	--	--	C
Primes 20-150 mm	∅ 87	B, R	B, R	B, R	B, R	B, R	B	--	--	B
ARRI/Zeiss Ultra Prime										
8 mm	∅ 134	--	--	--	--	--	--	--	P3	--
10 mm	∅ 156	P*	--	--	--	--	--	P2	P2	--
12 mm	∅ 156	P	--	--	--	--	--	P2	P2	--
14 mm	∅ 114	D, H, U	--	D, H, U	D, H, U	D, H, U	--	--	--	D
Primes 16-135 mm	∅ 95	C, T	C, T	C, T	C, T	C, T	--	--	--	C
180 mm	∅ 114	D, H, U	--	D, H, U	D, H, U	D, H, U	--	--	--	D
ARRI/Zeiss Super Speed Lenses										
all lenses	∅ 80	A, S	A, S	A, S	A, S	A, S	A, S	--	--	A, S
ARRI/Zeiss Ultra 16										
all lenses	∅ 95	A, S	A, S	A, S	A, S	A, S	A, S	--	--	A, S
ARRI Macros										
all lenses	∅ 80	A, S	A, S	A, S	A, S	A, S	A, S	--	--	A, S
Angenieux										
HR 7-81 mm	∅ 100	Z	Z	Z, VB100	Z, VB100	Z, VB100	--	--	--	--
11,5-138 mm	∅ 114	D, H, U	--	D, H, U	D, H, U	D, H, U	--	--	--	D
17-102 mm	∅ 144	N	--	--	--	--	--	--	--	N
HP 25-250 mm	∅ 110	K, W	W	W	W	W	--	--	--	--
HR 25-250 mm	∅ 136	M	--	--	--	--	--	--	--	--
Canon										
7-56 mm	∅ 95	C, T	--	C, T	C, T	C, T	--	--	--	C
8-64 mm	∅ 95	C, T	--	C, T	C, T	C, T	--	--	--	C
11-165 mm	∅ 95	C, T	C, T	C, T	C, T	C, T	--	--	--	C
11,5-138 mm	∅ 95	C, T	C, T	C, T	C, T	C, T	--	--	--	C
17-35 mm	∅ 95	C, T	C, T	C, T	C, T	C, T	--	--	--	C
Cooke S4i										
12 mm	∅ 156	P	--	--	--	--	--	P2	P2	--
14 mm	∅ 110	P	--	W	--	W	--	--	--	--
Primes 16-135 mm	∅ 110	K, W	W	W	W	W	--	--	--	--
150 mm	∅ 125	G, X, Y	X, Y	X, Y	X, Y	X, Y	--	--	--	--
Cooke Zoom										
10-30 mm	∅ 121	E	--	--	--	--	--	--	--	--
10,4-52 mm	∅ 125	G, X, Y	X, Y	X, Y	X, Y	X, Y	--	--	--	--
18-100 mm	∅ 150	O, Q	--	--	--	--	--	--	--	--
20-100 mm	∅ 144	N	--	--	--	--	--	--	--	N
20-250 mm	∅ 124	F	--	--	--	--	--	--	--	--
MK2 25-250 mm	∅ 121	E	--	--	--	--	--	--	--	--
T3.7 25-250 mm	∅ 150	O, Q	--	--	--	--	--	--	--	--
VANTAGE / HAWK										
10-24 mm	∅ 156	P*	--	--	--	--	--	P2	P2	--
150-450 mm	∅ 156	P	--	--	--	--	--	--	--	--
17-35 mm	∅ 110	K, W	W	W	W	W	--	--	--	--
Primes 15-180 mm	∅ 110	K, W	W	W	W	W	--	--	--	--

*) requires MB-14-W Carrier, K2.43957.0 AND two filter stage K2.45504.0 n.r.***) not recommended, can vignette, c.s.***)coming soon.

****) Shift and Tilt range limited by matte box, --) connection ring not available/not recommended

Germany

Arnold & Richter Cine Technik (Headquarters, Sales & Service)
Türkenstraße 89, D-80799 Munich, Germany
Tel: +49 (0)89 3809 0, Fax: +49 (0)89 3809 1245

Great Britain

ARRI GB Limited (Sales & Service)
2 Highbridge, Oxford Road, Uxbridge, Middlesex, UB8 1LX, Great Britain
Imaging Equipment Sales: Allan Fyfe, afyfe@arri-gb.com
Tel: +44 (0)1895 457 000, Fax: +44 (0)1895 457 001

Italy

ARRI Italia S.r.l. (Sales & Service, Milan)
Viale Edison 318, 20099 Sesto San Giovanni (Milano), Italy
General Manager: Antonio Cazzaniga, acazzaniga@arri.it
Tel: +39 (02)262 271 75, Fax: +39 (02)242 1692

ARRI Italia S.r.l. (Sales & Service, Rome)
Via Placanica 97, 00040 Morena (Roma), Italy
Camera Sales: Mauro Sembroni, msembroni@arri.it
Tel: +39 (06)79 89 021, Fax: +39 (06)79 89 02 206

USA

ARRI Inc. (Sales & Service, East Coast)
617 Route 303, Blauvelt, NY 10913-1109, USA
Vice President: Jürgen Schwinzer, jschwinzer@arri.com
Tel: +1 (845)353 1400, Fax: +1 (845)425 1250

ARRI Inc. (Sales & Service, West Coast)
600 North Victory Blvd., Burbank, CA 91502-1639, USA
Vice President: Bill Russell, brussell@arri.com
Tel: +1 (818)841 7070, Fax: +1 (818)848 4028

Canada

ARRI Canada Limited (Sales & Service)
415 Horner Ave. Unit 11 & 12, Toronto, Ontario M8W 4W3, Canada
Accounts Manager, Camera & Digital Systems:
Sébastien Laffoux, seb@arri.com
Tel: +1 (416)255 3335, Fax: +1 (416)255 3399

Asia

ARRI Asia Limited
Office 3B on 29/F, The Centrium, 60 Wyndham Street, Central, Hong Kong
General Manager: Paul Ivan, pivan@arri.com
Tel: +852 9018 2066, Fax: +852 3755 6371

Australia

ARRI Australia PTY Limited
Unit 6C, 5 Talavera Road, Macquarie Park NSW 2113, Sydney, Australia
General Manager: Stefan Sedlmeier, ssedlmeier@arri.com.au
Tel: +61 (2)9855 4308, Fax: +61 (2)9855 4301