



AATON 35 - III

User's Guide
June 97

The AATON 35-III User Guide

AATON
2 rue de la Paix
BP 3002
38000 Grenoble
FRANCE
+33 4 7642 9550
+33 4 7651 3491 fax
E-mail: support@aaton.com
Web: <http://www.aaton.com>

(c) June 1997 Aaton / Grenoble , France.

Limitation of Liability

The information contained in this manual is distributed without warranty of any kind, express or implied. To the maximum extent permitted by law, Aaton and its licensors disclaim any and all warranties, express or implied, by statute or otherwise, regarding this manual, including the fitness for a particular purpose, quality, or merchantability. Under no circumstances shall Aaton or its licensors be liable to the user of this manual or any other person for any incidental, special, or consequential damages resulting from the use of this manual or the operation of the equipment described therein, whether arising out of breach of warranty, breach of contract, or otherwise. Under no circumstances shall Aaton or its licensors be liable for any damages arising out of the operation of the equipment described in this manual, whether operated in a manner which is consistent with or contrary to the instructions contained therein, for physical abuse or misuse of the equipment. No oral or written information or advice given by Aaton or its licensors, their respective employees, distributors, dealers, or agents, shall create any warranty. Aaton and its licensors further disclaim any and all warranties, express or implied, by statute or otherwise, regarding this manual, including the fitness for a particular purpose, quality, or merchantability, regarding the equipment described in this manual, and in no event shall Aaton or its licensors be liable for any damages, including but not limited to incidental, special, or consequential damages, arising out of the use of the equipment, or any exposure of motion picture film used in the equipment.

1 GENERAL OVERVIEW

Front View	12
Rear View	13
Battery Side	14
Motor Side	15
LCD Control Panel - Quick Reference	16

2 THE CAMERA BODY

2.1 Lenses	20
Arri PL Lens Port	20
Installing the Lens	20
2.2 Viewing System	20
Viewfinder Options	20
Installing the Extension Finder	21
Viewfinder Tension Adjustments	22
Adjusting the Diopter	22
The Eyepiece Shutter	23
Adjusting the Viewing Horizon	23
Viewing Screen	23
Changing the Viewing Screen	24
Adjusting the Viewing Screen	25
2.3 Mirror Shutter	25
Concept	25
Adjusting the Shutter	26
2.4 Film Gate and Pulldown Claw	27
Adjusting the Pitch	27
The Side Pressure Bar	28
2.5 Flange Focal Distance Adjustment	28
Concept	28
Polishing a Spacer	28
Changing a Spacer	29
Adjusting the Viewing Screen	29
Flange Focal Distances	29

2.6 Magazine	30
Installing the Magazine	30
Removing the Magazine	31
2.7 Power	31
Installing the Battery on the Camera	31
Battery Charging	32
Other Power Options	32
2.8 Motor	33
Camera Speeds	33
Using External Speed Devices	34
Electronic Inching	34
Single Frame Operation	35
2.9 LCD Control Panel and Jog	34
The Aaton Jog	35
Understanding the Control Panel	35
AatonCode	36
ASA Setting	36
Battery Voltage	37
Magazine Number	37
Camera Preset Speed	37
Camera Specific Speed	37
Speed Phasing	38
Remaining Footage	38
Elapsed Footage	38
Camera Software Version Number	38
Footage Total Recall	39
Warning	39
2.10 LED Indicators	39
Position and Meaning of the Diodes	39
Camera Test Indicator	39
Camera Run Indicator	39
Low Battery Indicator	40
Low Speed Indicator	40
2.11 Video Assist	40
The CD56 Color CCD Assist	41
Installing the Control Unit	41

Menu Operations	42
-----------------	----

3 THE MAGAZINE

Concept	48
Pressure Plate System	48
The Gate Plate	48
The Picture Plate	48
Loading	49
First Step, in Daylight	49
Loading, in the Dark	50
Adjusting the Loop	51

4 THE AATON SYSTEM

Camera Configurations	56
15mm Front Rods	56
Sliding Bridgeplate	56
Handgrip	57
Mounting the Handgrip	57
Handgrip On/Off Functions	57
Handgrip Adjustment	58
Tripod Use	58
Shoulder Operation	58
Carrying Handle	59
3/8 Accessory Screw	59
Mounting from the Carrying Handle	59
Tape Measure Hook	59
Transport	60
Extreme Conditions	60
Cold Weather	61
Warm Weather	61

5 CLEANING

5.1 Lens	64
Lens Elements	64
Lens Exterior	64
Mounting Surface	64
5.2 Body	64
Exterior	64
Mounting Surfaces	65
Camera Gate	65
5.3 Viewing System	65
Viewing Screen	66
Eyepiece	66
Viewfinder	66
5.4 Magazine	66
Exterior	66
Pressure Plates	66
Interior / Film Path	67

6 SUPER35

6.1 Super35	70
The Format	70
When to Shoot Super35	70
6.2 Super35 Field Conversions	71
Changing the Viewing Screen	71
Shifting the Viewfinder	71
Shifting the PL Lens Port	71
Shifting the Video Assist	72

7 3-PERF FORMAT

7.1 Concept	76
7.2 The AATON 35-III 3-Perf Camera Body	76

8 AATONCODE

8.1 Concept	80
8.2 The Internal Clock	80
8.3 OriginC^{plus} MasterClock	81
8.4 Initializing AatonCode in the Camera	81
Using the OriginC ^{plus} - Recommended Method	82
Using an External SMPTE Device	82
8.5 Monitoring and Maintaining AatonCode	83
Monitoring AatonCode with OriginC ^{plus}	83
Maintaining AatonCode without OriginC ^{plus}	83
8.6 GMT1 Smppte Generator	84
8.7 The Camera's Assistant Duties	84
Checking the Diodes	84
Setting the ASA	85

9 TECHNICAL SPECIFICATIONS

List of Specifications	88
Connector - Pin Attributions	89
Viewing Screens	90

1

GENERAL OVERVIEW

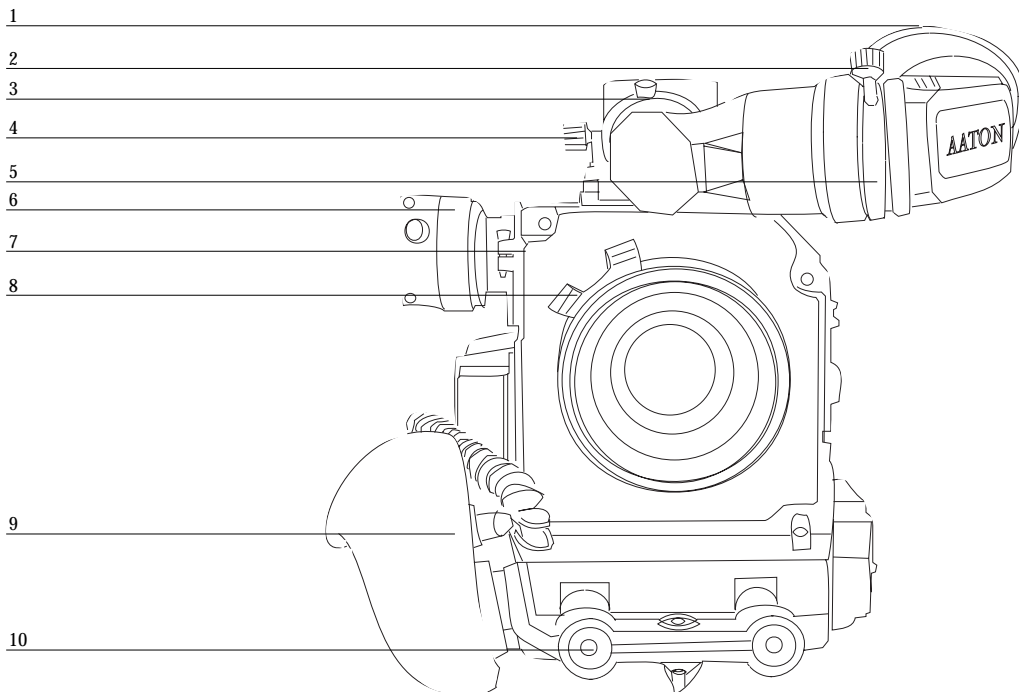

1.1 FRONT

- 1 Eyepiece
- 2 Friction Adjusting Ring adjusts the tension of the eyepiece swivel
- 3 Diopter Set Ring adjusts the diopter setting of the viewfinder to the operator's eye
- 4 Lateral Lock Knob locks the lateral position of the viewfinder
- 5 PL Lens Port
- 6 CCD Control Unit
- 7 CCD Friction Ring
- 8 Lens Locking Ring
- 9 Wooden Handgrip
- 10 15mm Front Rods

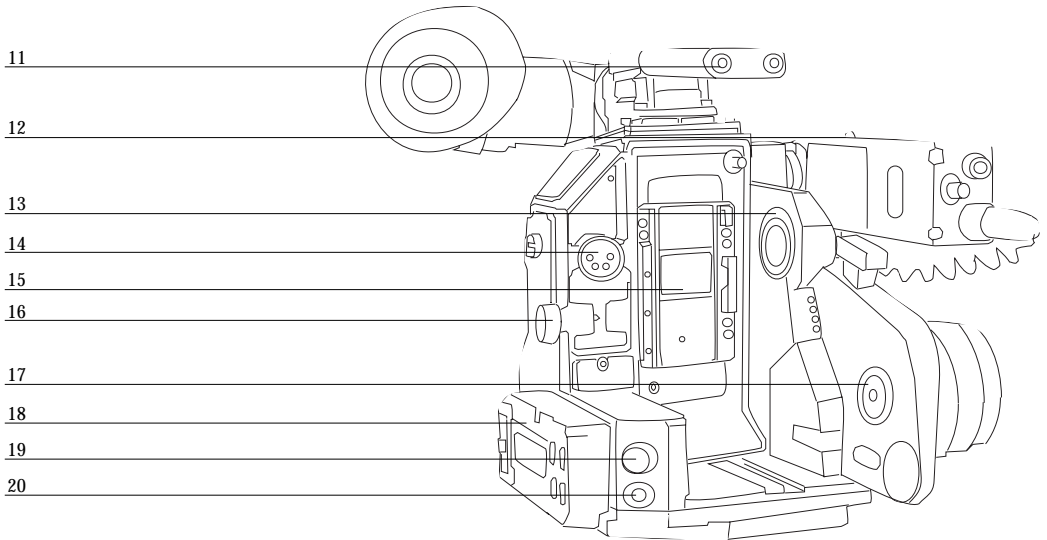

1.2 REAR

- 11 Pitch and Mirror Shutter Adjusting Tools
- 12 CCD Led - On/Off indicator
- 13 Magnetic wheel for the magazine's sprockets
- 14 XLR4 Connector allows for the battery connection
- 15 Aperture Opening
- 16 Battery Locking Screw
- 17 Magnetic Wheel for the magazine's take-up core
- 18 LCD Control Panel displays AatonCode, ASA, speed, voltage, or remaining footage
- 19 Jog Wheel provides quick adjustment of ASA, speed, and phasing
- 20 Lemo5 Connector for AatonCode and SMPTE communication

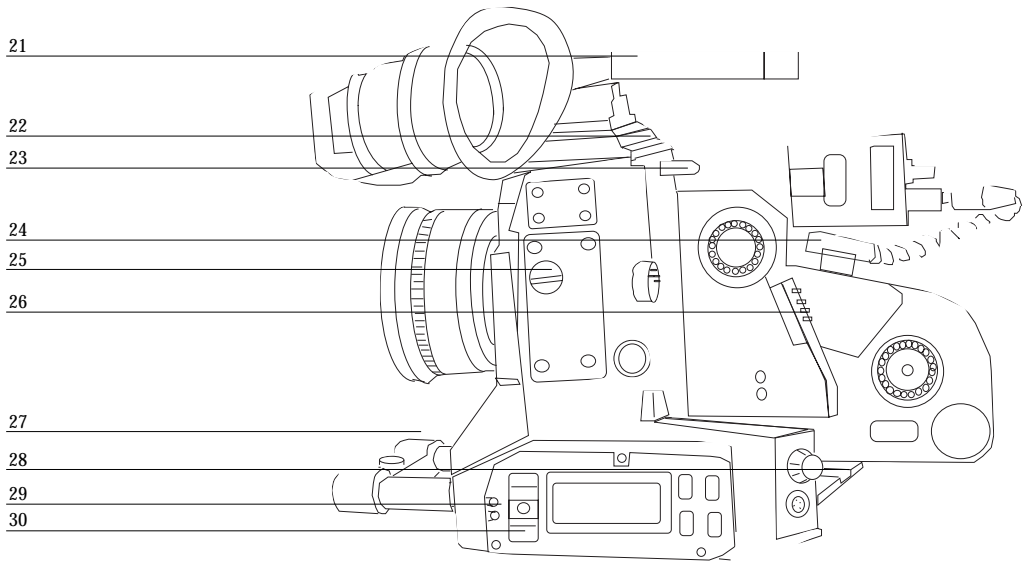

1.3 BATTERY SIDE

- 21 Carrying Handle
- 22 Base of the carrying handle and viewing system block
- 23 Guiding Pin for the magazine
- 24 Amph9 Connector connects the CCD unit to the camera body
- 25 Cap covering the viewing screen holder
- 26 Magazine Connector
- 27 Coupler allows for the handgrip attachment
- 28 Guiding Grooves for the Magazine
- 29 LED Indicators
- 30 Run/Test Switch provides camera Run and half frame inching

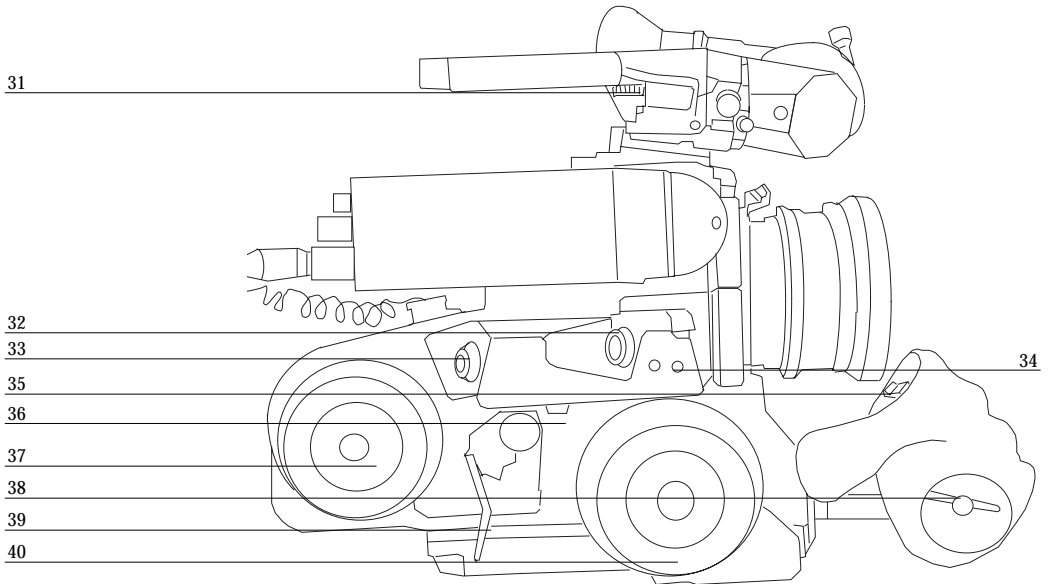

1.4 MOTORS SIDE

- 31 Eyepiece Shutter blocks light when operator's eye is away from the viewfinder
- 32 Lemo6 Connector
- 33 Lemo8 Connector
- 34 Led Indicators
- 35 Handgrip Run/Test Switch provides camera run and full frame inching
- 36 Lemo2 Connector
- 37 Magazine's Take-up Core Motor
- 38 Handgrip T-Screw
- 39 Mag Release Lever
- 40 Magazine's Sprockets and Camera Pulldown Claw Motor

1.5 LCD CONTROL PANEL - QUICK REFERENCE

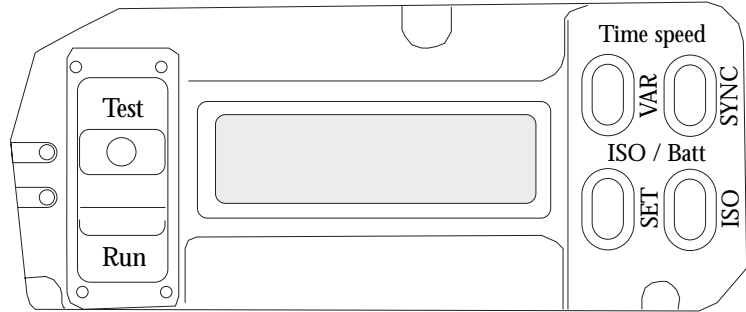

IN SHOW MODE

24' - 080	Camera speed and Remaining footage	(default mode)
ISO = 100	Film ASA	(1 x Batt/Iso)
Batt = 10'4	Battery voltage	(2 x Batt/Iso)
MAG =0071	Magazine number	(3 x Batt/Iso)
Sp = 27'454	Camera Speed	(1 x Speed)
Ela = 042	Elapsed footage during last take	(2 x Speed)
22=32=54	Hours=minutes=seconds in AatonCode	(1 x Time)
95-03-25	Year-Month-Day in AatonCode	(2 x Time)
123456	Production ID in AatonCode	(3 x Time)
2321	Equipment number in AatonCode	(4 x Time)

IN SET MODE

Sp =2 4'	Adjusting a preset speed	(SET, 1 x SYNC, toggle SYNC or use Jog)
Sp = 27'454	Adjusting a specific speed	(SET, 1 x VAR, use Jog)
Et	Speed controlled by external speed device	(SET, 2 x VAR)
Phase	Phase Adjusting	(Camera running,SET, 2 x VAR, use Jog)
ISO = 100	ASA Setting	(SET, 1 x ISO, toggle ISO or use Jog)

WARNINGS

Lo Spd	Camera has not yet reached the selected speed
Lo Batt	Battery is too low (below 10V)
Loop	Film loop is too small
Scratch	Something is wrong in the magazine
Empty	No more film in the magazine
Unadjust	Please check page 39

2

THE CAMERA BODY

2.1 LENSES



Flange focal distance.

Refers to the critical distance from the lens seat to the film plane. With the PL port, the precise FFD of the AATON 35-III is 52mm -40 to -50 microns as measured with a depth gauge in the lens port. With the PV port, the FFD is 57.15mm -60 to -70 microns. It is recommended that these tolerances be checked and maintained by a qualified technician. The combination of FFD and back focus distance of a lens directly affects precise focus and overall image sharpness. Make sure these critical measurements are strictly upheld. When using an unfamiliar lens for the first time, check that the eye focus matches the tape-measured focus marks on the lens, and/or shoot a focus test.

The AATON 35-III's flexible lens mounting system allows for the use of a wide variety of 35mm lenses.

2.1.1 ArriPL Lens Port

The ArriPL lens port is the standard mounting system delivered with the AATON 35-III and allows the use of all 35mm ArriPL mounted motion picture lenses. PL lenses adaptors are available for Arri standard and Arri bayonet mounted lenses. This lens port is ideal for rental facilities, where a mounting system compatible with other manufacturer's 35mm cameras is often desired.

If you need to get a Panavision or Nikon mount, please contact a certified Aaton technician.

2.1.2 Installing the Lens

To install the lens on the camera body, turn the outer locking ring counter-clockwise. If the port cap is on, remove it. Align the four protruding flanges on the lens with the four corresponding cutaways in the locking ring and insert the lens into the camera port so that its flanges rest evenly against the lens seat. Tighten the locking ring by turning clockwise until the lens is secured in place and the locking ring is firmly set. Make sure the locking ring is tight enough so that it cannot be inadvertently unlocked.

VIEWING SYSTEM

2.2.1 Viewfinder Options

The viewfinder is designed to be fully orientable, providing left or right side viewing and upright image in any position. The viewfinder comes equipped with a standard short eyepiece that can be used for handheld and tripod-mounted operation. For more comfortable tripod and studio applications, the standard extension finder(200 mm) can be fitted in place of the short eyepiece. With an Elemak or

pin on the seat of the viewfinder and align the pin with the hole in the flange of the finder. Make the flange to the seat of the viewfinder and tighten the lock ring until it is set firmly in place. During this procedure, you will notice that the extension finder needs to face 180° away from the operator's eye to be installed on the viewfinder. Because of its optical construction, this is completely normal. After installation, rotate the finder 180° to regular viewing position.

2.2.3 Viewfinder Tension Adjustments

The large knurled knob at the base of the left/right lateral movement point (B) locks the lateral positioning.

The friction adjusting ring, located behind the eyepiece lock ring, can be used to adjust the tension of the eyepiece swivel, depending on the operator's preference and the viewfinder being used.

When using the standard eyepiece, tension should be relatively light to allow for movement with a moderate amount of pressure.

When using a standard extension finder, tension should be increased to hold the additional weight of this finder in place.

To adjust the tension of the swivel, loosen the steel knurled screw (C) located on the friction adjusting ring. Hold the eyepiece in place, rotate the adjusting ring slightly and retighten the screw; 1/8 of a turn, at first, will have an effect. To increase the tension of the eyepiece swivel, rotate the adjusting ring clockwise; to decrease the tension, rotate the adjusting ring counter-clockwise.

2.2.4 Adjusting the Diopter

Before shooting, the diopter setting of the viewfinder should be adjusted to the operator's eye. To set the diopter, locate the diopter set ring (D) in front of the carrying handle at the top of the viewfinder, and loosen the small knurled knob. Look through the viewfinder, rotate the diopter set ring until the edge of the cross-hair is at its sharpest point and retighten the knob. It is recommended that, for easiest setting, this adjustment be performed with the port cover off and no lens on the camera.

Notice that the diopter set ring is engraved with numbers and dots

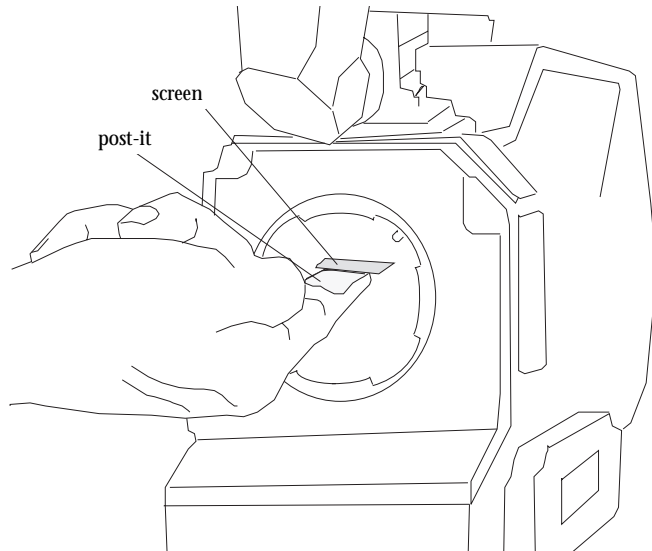

The viewing screen is designed to be easily removed by the user for the purpose of interchanging or for cleaning. To remove the screen, first remove the port cap. Remove the battery and clear the mirror shutter so that it is positioned safely inside the body by rotating at the base of the shutter with your finger. Look into the port and locate the screen directly above the aperture opening. To operate, use a piece of Post-it, that will take the viewing screen without dirtying it. Put the Post-it on your forefinger, the sticking part of it facing up. Smoothly put your finger on the viewing screen, and remove it.

To reinstall the screen, look into the port and locate the right and left lip of the viewing screen holder. The grounded side of the viewing screen should face down. Proceed as before, with a piece of Post-it on your finger.

2.2.9. Adjusting the viewing screen :

The image focus on the viewing screen (or “ground-glass”) should match the lens barrel focus mark and the focus on the film. Before adjusting the viewing screen, be certain that the flange focal distance

of the camera is set according to the manufacturer specifications. 52 mm, 57.15 mm and that the lens used is correctly adjusted ; this can be determined by the use of a collimator. It is preferable to use a "wide angle lens" i.e. : less than 25 mm. To proceed, you must first unscrew and remove the circular Cap located on the upper side of the rectangle plate, above the battery locking screw. Inside the access hole, locate the screen holder that you can unlock by turning its Allen screw counterclockwise. Set your focusing chart at a measured distance. Set the focus mark of the lens at the exact same distance (Adjust the diopter !) you can, now, focus the ground-glass, moving the holder up or down by turning the Aaton two pins tool. Lock the Allen screw. Double check the focus of the viewing screen using the focus ring of the lens. If the image is still not sharp, proceed again.

2.3 MIRROR SHUTTER

2.3.1 Concept

The reflex mirror shutter is designed to provide an optical path to the viewfinder while the claw movement advances the film to the next frame.

The shutter features a four-position user-adjustable opening.

- **Standard 180° for filming**
 - under standard 60 Hz HMI lighting at 24 fps
 - or under standard 50 Hz HMI lighting at 25 fps
 - without flicker.
- **172.8° for filming**
 - under 50 Hz HMI lighting at 24 fps
 - without flicker.
- **150° for filming**
 - under 60 Hz HMI lighting at 25 fps



Always Remove the Battery

Each time you need to go inside the camera body, you must first remove the battery. If, by mistake, the camera starts running while you finger is rotating the mirror shutter, the mechanism of the camera body could be seriously damaged.

without flicker.

- 144°
to minimize the roll bar while filming
NTSC broadcast monitor at 24 fps.

2.3.2 Adjusting the shutter

To adjust the shutter opening, unscrew the shutter tool marked “Sh” located in the hollow at the rear of the camera’s carrying handle. Make sure that the battery is off the camera and remove the port cap. Locate the tool guiding hole to the lower right of the inside lens holder. Gently rotate the shutter at its base with your finger until the brass driving gear is centered underneath the tool guiding hole. Insert the shutter tool through the guiding hole and into the brass gear. Rotate the tool until the appropriate notched shutter setting is reached ; turning counter-clockwise will reduce the shutter opening, turning clockwise will increase the opening.

When setting the opening to 172.8°, 150° or 144°, a shutter blade indicating these settings will be visible from behind the left edge of the mirror. Make sure the white line to the immediate right of the 172.8°, 150° and 144° markings meet the left edge of the mirror.

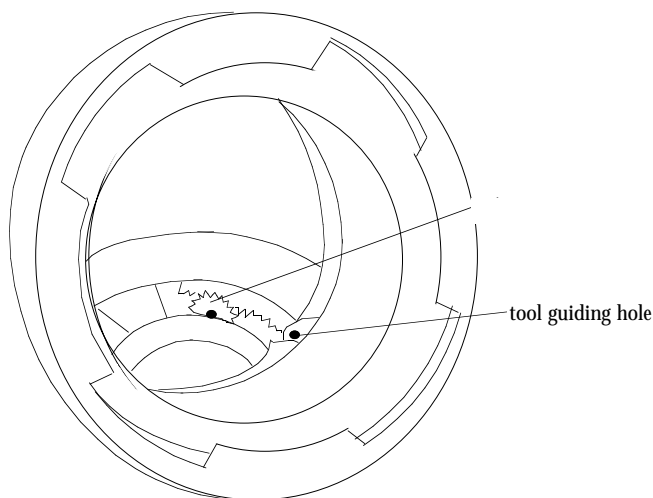

When the adjustment is complete, remove the tool and store back in the hollow of the carrying handle.

2.4 FILM GATE AND PULLDOWN CLAW

2.4.1 Adjusting the Pitch

To adjust the pitch, use the tool (Ref 09.203.65) located at the rear of the camera carrying handle.

Looking at the camera with the lens port facing you, locate the small opening situated between the two camera front rods, closer to the left rod. Using the tool, you can undo the Allen screw retaining the opening cover. Insert the tool inside the opening. You will "feel" a screw that you will turn counter-clockwise until it stops. The length of the pulldown is now at its maximum.

Put the loaded magazine on the camera, and keeping the tool in position, inch and run the camera. The camera will run with a "clicking noise", due to the perf being hit by the claw. Turn the tool clockwise until you reach a more pleasant noise, like a loud "purring". If you go too far, you will hear one "clack" noise indicating that the claw lost a perforation. If more than one "clack" is heard, the camera display will show "LOOP".

Once you reach the proper setting, it is recommended to turn the tool counterclockwise, approximately 20°, to accommodate any variation of the film pitch that occurs between different film stocks or under humid or hotweather conditions. To do this adjustment, use the film stock you are most likely to use.

2.4.2 The Side Pressure Bar

The film gate also features a side pressure bar which is recessed into the claw-side rail at the point of image exposure to insure maximum lateral stability.

2.5 FLANGE FOCAL DISTANCE ADJUSTMENT

2.5.1 Concept

For a few years now, Aaton has inserted a spacer between the lens port and the camera body. This thin (0.3mm) metallic ring is responsible for the precise distance between the lens port seat and the film plane called the flange focal distance (FFD), and therefore it is also mainly responsible for the sharpness of the images.

In order to change the FFD of the AATON 35-III, simply change the spacer, and only the spacer. Do not polish any other surface, or insert anything else between the lens port and the film plane. For fine adjustment of the FFD, order some aluminium spacers (0.35mm) from your Aaton agent, and then safely change the FFD of your camera.

2.5.2 Polishing a Spacer

In order to fine-adjust the thickness of a specific spacer, Aaton carries a specific tool (ref 35 310 32) designed to hold the spacer firmly and evenly against polishing paper. When polishing a spacer, always work on a perfectly flat worktable or stone, and be sure to firmly hold the tool.

2.5.3 Changing the Spacer

The spacer is placed between the PL lens port and the camera body's titanium base. First, remove the lens locking ring: screw two or three turns its stop (placed on the bottom, inside the PL port), and turn the ring counterclockwise. Remove the PL port by unscrewing its 6 screws. Then gently remove the aluminium spacer .

Once you have placed a new spacer, install the PL port, then the lenses locking ring, and do not forget to unsrew two or three turns the locking ring stop.

2.5.4 Adjusting the Viewing Screen

Because you have changed the distance separating the base of the lens and the camera body, the image on your viewing screen might now appear to be less sharp than usual. Most likely, you may need

to readjust the precise focus of the viewing screen. Refer to the 2.9 section of this chapter to proceed.

2.5.5 Flange Focal Distances

Here are the flange focal distances for all the lens ports available for the AATON 35-III. Remember that these distances are automatically shorter by 0.3mm than the indicated ones (because of the needed spacer)

2.6 MAGAZINE

Mount	Référence	FFD	Diameter	Adjustment
Arriflex (PL)	35 340 30	52.00 mm	54.00 mm	-40 / -50 microns
Panavision (PV)	35 330 30	57.15 mm	49.50 mm	-60 / -70 microns
Nikon (Ni)	35 360 10	46.44 mm	43.53 mm	-40 / -50 microns

The Aaton magazine holds 400ft (122m) of 35mm film, which represents 4'28" shooting at 24fps in 35mm 4-Perf, and 5'26" shooting at 24fps in 35mm 3-Perf.

2.6.1 Installing the Magazine

To install the mag, situate yourself at the rear of the camera body, battery side. Do not forget to remove the aperture plate cover. Place your left hand underneath the magazine while your right hand is firmly holding it at the midway point of its rear. Rest the nose of the magazine on the camera base, hold the camera body with your left hand while pushing the mag in the bottom dovetail and into the aperture area with your right hand. Make sure that the top of the "nose" of the mag is parallel to the camera carrying handle as you guide the mag in place. Push firmly and evenly until you feel and hear that the mag snaps against the aperture area. The mag nose should be pressed against the camera body's rubber seal. This operation should be done without having to force the mag into position.

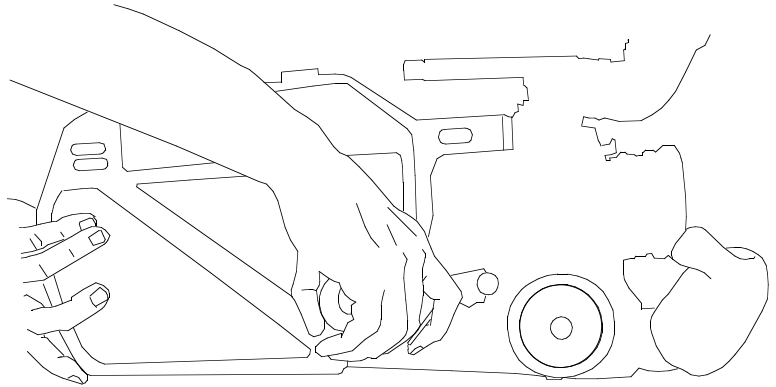

2.6.2 Removing the Magazine

To remove the magazine, situate yourself at the rear of the camera body, battery side. Place your right hand palm on the camera take-up motor and pull the mag lock lever towards the rear of the camera with your fingers.

The mag will be toward the rear of the camera. The mag is now free to be pulled off the camera, using both your hands.

2.7 POWER

The AATON 35-III body requires only 12 volts for all aspects of operation. One standard Aaton on-board (12V, 1.8 Ah, rechargeable, nicad) will power the camera, CCD and accessories which are connected to the body's accessory inputs (such as zoom controls, speed controls, etc.) through a standard 4 pin XLR connector. One 1.8 ah on-board battery will run 7-8 magazines on the AATON 35-III, without CCD and accessories. With accessories in use, this number will decrease.

2.7.1 Installing the Battery on the Camera

The on-board battery fits above the LCD control panel. In order to install, loosen the black knurled screw approximately four or five turns. Push the battery evenly onto the XLR4 connection of the

body. When snug, tighten the knurled screw onto the battery tab to hold it in place.

When running AatonCode, get into the practice of having a fresh battery on hand before removing the one from the camera. Even a low battery that no longer runs the body (below 10V) will have enough voltage to keep accurate time counting.

Thanks to a super capacitor built into the camera base you will have a full minute to change the battery before time is lost. After replacing the battery, confirm that time is still counting by checking the control panel.

2.7.2 Battery Charging

The Aaton on-board can be recharged with an appropriate 12V nicad battery charger.

For the best results, use a microprocessor-controlled charger or a standard trickle charger with a charging output of at least 200ma,

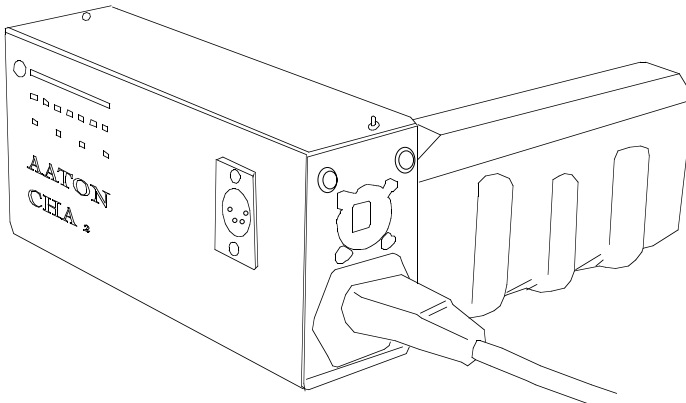

both of which prevent of the overheating and mistreatment of your nicad cells. Always follow the specific guidelines of the charger manufacturer. You can use the Aaton Chr1, designed to charge two standard batteries in 6 hours, without any risk.

Beware of older, timed chargers manufactured when 1.2 and 1.4ah



Nicad Battery Tips

Follow a few simple rules to insure the long life of your nicad cells:

- Allow the battery to run through their normal cycle of charging and use. Avoid topping off partially full batteries. Once every few months, discharge cells to 8-10V using a standard discharger to minimize their memory.
- Do not rapid-charge your cells more than necessary, as the added heat will eventually shorten their life span. Instead recharge batteries at a normal charging rate when your schedule allows.
- If your batteries will not be used for long periods of time, always store them in a cool dry environment fully charged.

batteries where the norm; these chargers were most likely rated for the lower amperage batteries of that time and will consistently undercharge the higher rated nicad cells of today.

2.7.3 Other Power Options

Since the AATON 35-III power input is a standard 4 pin XLR type, a great variety of 12-14 volt sources can be used to power the camera. This includes AC power supplies, battery blocks, lithium cells and car batteries.

Get into the habit of carrying a standard XLR4 powercable in your package in case an alternative power source is needed.

Regarding AC power supplies, it is recommended that the unit you use be at least 5 A and 25 W. Before connecting any non-standard source, always make sure that the pin configuration of the unit is correct. See the Technical Specifications chapter of this manual for details for proper wiring.

2.8 MOTOR

The tri-phase samarium design of the AATON 35-III provides low power consumption and improved stability at high speeds. The body is capable of speeds between 3 and 40 fps with a standard 12V battery.

2.8.1 Camera Speeds

The AATON 35-III provides both preset crystal speeds (in sync mode) and specific crystal speeds (in variable mode) in .001 increments, all accessible from the LCD control panel.

Available preset speeds consist of 6, 12, 18, 23.98, 24, 25, 29.97 and 30. The preset speed selector (SYNC) allows for quick access to these frequently used speeds.

If any other speed is desired, or if the camera speed must match the frequency of a monitor to eliminate a roll bar, the specific speed selector (VAR) should be employed. The specific speed selector

enables the body to run at any speed between 3 and 40 in .001 frame increments. A phase adjustment of the variable speed is accessible from the VAR selector and jog wheel.

The camera speed can also be adjusted while the camera is running in either sync or variable mode. For more information on these speed functions, refer to section LCD Control Panel and Jog of this chapter.

2.8.2 Using External Speed Devices

The AATON 35-III can be driven externally from devices such as film/video synchronizers, speed aperture computers and external speed controls. In these situations, the camera VAR selector must be set to Et. If such a device is connected and the selector is not set to Et, the camera will run at the speed indicated on the display.

Keep in mind that, with certain manufacturer's speed controls, it may be possible to run the camera at speeds higher than the 40 fps factory limitation. Overcranking in such a way, however, will increase mechanism wear, increase noise and compromise image registration. Aaton urges to avoid such usage at all cost and will not be responsible for the resulting damage that will occur. This top speed cap of 40 fps has been designated by Aaton because it is the limit at which the camera can run safely without any adverse effects on its mechanics.

2.8.3 Electronic Inching

The inching function of the motor is accomplished electronically and can be accessed in a number of ways.

From the Handgrip

The wooden handgrip switch, by way of the lemo2 connector, provides camera run and full frame inching for single frame operation and loop situating.

From the LCD Control Panel

The run/test switch, besides the LCD control panel, not only runs

the camera, but provides half frame inching for gate inspection and loop situating when installing a fresh mag.

From a Remote Cable

The Lemo2 connector, as well as Lemo6, Lemo8 and Amph9 accessory connectors, provide the capability of using a remote on/off with either a half-frame or full-frame inching function.

2.8.4 Single Frame Operation

With the use of electronic inching switch via the wooden handgrip or a remote cable, the AATON 35-III can be used as a simple intervalometer for single frame operation. Each frame is 1/4 sec exposure.

2.9 LCD CONTROL PANEL AND JOG

The AATON 35-III utilizes a straightforward and intuitive control panel structure in conjunction with a small jog wheel to access and adjust all operator functions.

2.9.1 The Aaton Jog

Located to the immediate right of the LCD control panel, Aaton Jog is a small wheel designed to simplify many user functions. When used in conjunction with the control panel the jog allows for quick adjustment of some of the otherwise time-consuming parameters (such as the setting of a precise 5-digit speed or a film short end).

2.9.2 Understanding the Control Panel

The control panel consists of a LCD display and four buttons to access information. The control panel operates in two modes: Show and SET. To show a parameter without adjusting, go directly to one of the black function buttons to view relative information. To set a parameter, first press the white SET button, then go to the appropriate function. Information is changed by either toggling that but-

ton ot by rotating the jog, depending on the parameter. Pressing SET afterwards (or waiting for 7 seconds) will enter your selection. Capped text (SYNC, VAR, ISO) refers to those functions adjustable while in the SET mode; standard text (Speed, Time, Iso/Batt) refers to those functions accessible directly in the default Show mode.

Note that, while viewing a Show function on the control panel, any inactivity longer than 10 seconds will revert the display back to its default mode (speed and remaining footage). As mentioned previously, any break longer than 7 seconds while in SET mode will automatically enter the last selection.

The following parameters can be accessed from the LCD control panel in conjunction with the jog. For more concise information see the table in the System Features and Controls chapter of this manual.

2.9.3 AatonCode

As a standard feature the AATON 35-III is equipped with the capability of recording AatonCode in-camera time. TimeCode information is exposed onto the film by optical projection of seven micro-diodes into the gate to the left of the aperture opening. These micro-diodes flash rapidly to form the code as the film rolls through the gate between exposures.

AatonCode is initialized in the camera, in ASCII or SMPTE form, through the Lemo5 connector located to the right of the LCD control panel. For the most straightforward and reliable communication, OriginCplus, Aaton's masterclock, comparator, and SMPTE generator device, should be used.

If AatonCode has been initialized in the camera, press button Time to view timecode information. Toggling button Time will display hours/minutes/seconds, then year/month/day, then the six-digit production ID, then the camera's equipment #, in that order.

2.9.4 ASA Setting

When using AatonCode in the AATON 35-III, the ASA(ISO) setting must be adjusted to the exposure index of the film stock being



Force Processing and the AatonCode matrix

Regardless of the situation, always set the ASA selector to the actual exposure index of the film. If you know beforehand that your footage will be pushed or pulled, don't worry about compensating for the sake of the precise exposure of your timecode matrix. The matrix is resistant enough to handle exposure variances of one and a half stops or more in either direction.



Changing Speeds while Running the Camera

Any camera speed, whether preset or specific, can be changed when the camera is running. To do so, run the camera, then follow these simple steps:

- Operating under a preset speed (in sync mode), press SET, then SYNC, then use the jog wheel to choose a higher or lower stepped speed.

Under a specific speed (in variable speed), press SET, then VAR, then use the jog to ramp the speed higher or lower in .001 frame increments.

used. The ASA/ISO selection will insure that the timecode matrix recorded on the edge of the film in the gate will be exposed at an appropriate and useable level.

If AatonCode is not running in the camera, the setting of the ASA/ISO will have no effect.

Press button Iso/Batt twice to view the ASA selection.

Press SET then button ISO, to adjust the ASA setting. Make your selection between 25 and 1000 ISO by toggling ISO or by rotating the jog wheel.

If the ISO selector is adjusted while the camera is in test or run position, the correction will not take place until the next camera start.

2.9.5 Battery Voltage

Press button Iso/Batt to read the voltage of the camera's power source. Notice that if the camera is running and button Iso/Batt is pressed, the control panel will read and display the voltage under load.

2.9.6 Magazine Number

As soon as a magazine is installed in the camera, you can read its number ID by pressing Iso/Batt three times.

2.9.7 Camera Preset Speed

The default mode of the control panel will automatically display the camera speed selection, whether it be in sync or variable mode, when the camera is powered but not running. When the camera is turned on, the actual running speed to the .01 frame is displayed. To adjust the preset speed, press SET, then button SYNC. Make your selection of stepped crystal speed between 6 and 30 fps by toggling SYNC or via the jog wheel.

2.9.8 Camera Specific Speed

To choose a specific speed press SET, then VAR. Make your selection of any .001 incremented crystal speed between 3.000 and 40.000 fps via the jog.

To set the camera to be driven from an external source (such as film/video synchronizer or external speed control), press SET, then VAR twice. Et will be displayed, indicating that camera is set in external mode.



2.9.9 Speed Phasing

The phasing of the variable speed can be set to eliminate a roll bar while filming a monitor. Operate first with no magazine on the camera, because you first need to synchronise the camera speed to the monitor frequency. Run the camera. Press SET, then VAR once, turn the jog, until the roll bar seems stable on the screen. Press SET to enter. Stop the camera, and then install a magazine. Run the camera. Press SET, then VAR twice. Look through the camera at the monitor and turn the jog until the roll bar is out of view. Press SET to enter.

2.9.10 Remaining Footage

The control panel will display the footage remaining any time the camera is running with a magazine on. The displayed footage is calculated by the magazine itself: it is determined by the measure of the feed core speed. To modify the footage measurement unit, press ISO, then TEST and then ISO again to modify.

2.9.11 Elapsed Footage

With the camera stopped, press Speed twice, to view the elapsed footage of the previous camera run. With the camera running press Speed twice to view the elapsed footage of that particular take. The display will revert back to its default mode (speed and remaining footage) after 10 seconds.

2.9.12 Camera Software Version Number

If you need to know the software version number your camera is equipped with, proceed as follows. Unplug the battery from the camera. Put the camera on Test mode. Then, while installing the battery, watch the LCD control panel carefully. During one second it will display something like: T4 V2.08, indicating that you own a



Displaying a 5 Digit Speed

If the AATON 35-III is set to a variable (5-digit) speed, the control panel will only display that speed to the .01 digit. Keep in mind, the display will not round off the speed, but simply leave off the last digit. For example, if the 5 digit speed of 23.976 is entered, the control panel will display 23.97, not 23.98.

Remember... Variable Speed for Phasing

Keep in mind, the speed phase function of the control panel will only operate when a variable speed is initially selected.

When shooting 29.97, for example, be sure to choose the specific 29.970 instead of the preset 29.97 if you plan to incorporate the phase function for that particular shot.

35mm 4-Perf camera, working with the software version number 2.08.

2.9.13 Total Footage Recall

To find out total footage run through the camera since manufacture install, hook up a battery onto the camera body, press SYNC and flip the switch to TEST. The footage displays in thousands of images.

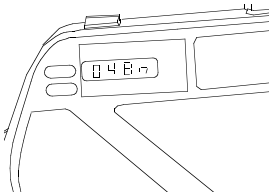

2.9.14 Warning

If for some reason the camera loses its programming parameters, "UNADJUST" will flash regularly, leaving the camera functioning. The TCXO then uses default frequency adjustment, insuring a TimeCoding precision of 10^{-4} instead of 10^{-6} .

2.10 LED INDICATORS

The AATON 35-III utilizes LED indicators in three locations to convey information: in the viewfinder and on both left and right sides of the camera body.

2.10.1 Position and Meaning of the Diodes

- Two yellow diodes, placed on both right and left sides of the camera body indicate that the camera is either on Test or on Run mode.
- Two red diodes, placed on both right and left side of the camera body, and a third one, visible from the view finder, display a special warning.

2.10.2 Camera Test Indicator

- Yellow diode is on.
- Red diode is blinking fast.

2.10.3 Camera Run Indicator

- Yellow diode is on.
- Red diode is off.

2.10.4 Low Battery Indicator

- Yellow diode is on.
- ● ● Red diode is evenly flashing.

The LCD control panel displays Lo Batt.

2.10.5 Low Speed Indicator

- Yellow diode is on.
- ● ● Red diode is blinking fast.

The LCD control panel displays Lo Speed.

2.11 VIDEO ASSIST

The AATON 35-III accept 4 different video assist: CD52 PAL, CD52 NTSC, CD56 PAL and CD56 NTSC. The CD52 are black & white, and the CD56 are color.

The control units for all Aaton CCD assists attach quickly to the camera's housing and can be used with an on-board battery. The video assist may be used to help the director or operator control their images, or to prepare the video editing, before the telecine stage.

The following chapter is mostly dedicated to the CD56, which is Aaton's high-end model, and is designed to offer high quality, flicker-free color video assist imaging, burn-in windows, Vitec insertion and a frame line generator in one integrated system.

2.11.1 The CD56 Color CCD Assist

You may use the CD56 color CCD assist in two different ways. In some special situations (if you're filming in the dark for example), it might be more comfortable to look your images on a monitor than through the viewfinder. This is why the CD56 is equipped with a frame line generator: as you can choose the size and position of the generated frame, the image you see through the viewfinder (which might be in ratio 1.78 or 1.66 for example) can match exactly the image you see inside the frame on the monitor. Moreover this



Beware of the high power consumption of the video assist

The CD56, as well as the CD52, is equipped with an On/Off switch. As soon as you have finished with using the video assist, switch it to off. Keep in mind that a CD56 needs up to 700 mA to run.



Vitc lines

- First line is the video timecode line. Each time you switch on the video assist, the video timecode is set to 1:00'00" 00 (the last number is the image number). Then as soon as the AATON 35-III is running this time is incremented.
- Second line is the keycode line. As the keycode should be read from the film, this line cannot be generated. Only synchronization and checksum bits are inserted.
- Third line is the audio timecode line, i.e. all the timecode information of the AatonCode is inserted here.

frame is easier to locate than the viewing screen's frame. The director can then immediately control his operator's images.

Of course, the video assist was first created to be used in such a way. But, now that video editing (including the virtual video editing) offers new powerful tools to the editor, the CD56 can be used in a different way. The CD56 provides a Vitc lines generator, which are the dots and lines, usually put above the video image, used by video editing machines. Therefore, images recorded by the video assist may be directly used to make a video editing of the film; no need to wait for telecine, no need also to have developed the rushes you won't use.

2.11.2 Installing the Control Unit

All of the CCD assists available for the AATON 35-III can be easily attached on the camera body, in a few seconds without the need for adjustment.

First locate the video port, above the Lemo 6 connector on the motor side of the camera. Using an Allen wrench, loosen 3 or 4 turns its small black screw. Remove the plastic port cover. Check that the exposed lens of the CCD video assist is free of dust particles. If

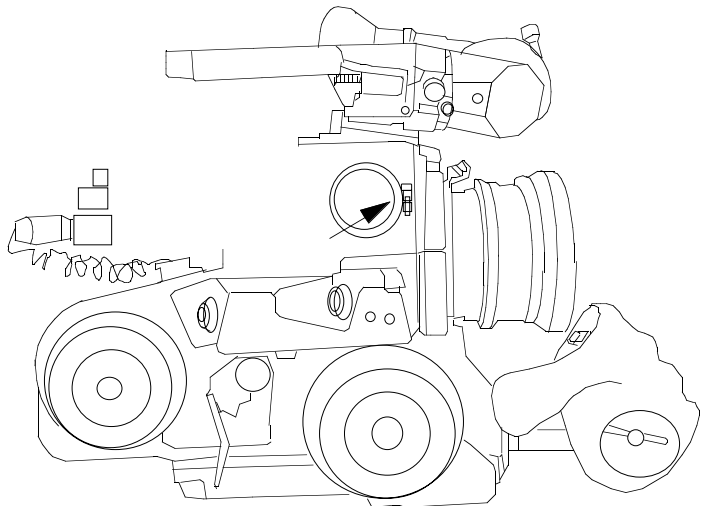

necessary, clean this surface with lens fluid applied with a cotton Q-tip. Install the lens into the camera video port. Connect the control unit cable to the camera body through the Amph9 connector. Connect a BNC cable to the monitor and power the AATON 35-III. Turn on the toggle switch of the CCD Unit, the yellow diode should light. Set the video assist iris wide open, and while looking at the monitor, move the whole control unit until the viewing screen image is in focus and square to the monitor. Rotating the unit controls the image horizon, pulling or pushing it controls the image focus. Tighten the Allen set screw to lock the control unit in position. If the camera lens mount has been shifted from 35 to super 35, loosen the video tap retaining the screw and refocus.

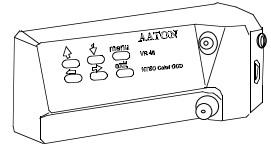

2.11.3 Menu Operation

The CD56 unit contains six operator buttons: up, down, left, right arrows, menu and exit keys.

Press MENU to have the menu displayed.

Use arrows to access to the desired parameter.

Press MENU to indicate that you want to modify this parameter.

Use arrows to adjust this parameter.

Press MENU to validate

Press EXIT to memorize the new configuration.

• Std

Choose the video image frequency you need between 24 and 25 frames per second. Keep in mind that choosing 24 fps, provides a non standard video signal, that you won't be able to record.

• Color Temp

Depending on the kind of film you're using (a film for inside or a film for outside) the colors it will register will not be the same. To have the video colors closer to the film colors, you can choose between 3200K (tungsten) and 5600K (daylight).

• Date

Date allows you to choose the position of the current date insertion

inside the video image. Use the arrows to proceed.

• **Time**

Time allows you to choose the position of the current time insertion inside the video image. Use the arrows to proceed.

• **Cam**

Cam allows you to choose the position of the magazine number insertion inside the video image. Use the arrows to proceed.

• **Frame**

Frame/Frame On-Off allows you to choose if you want (On) or not (Off) a frame to be inserted in the video image.

Frame/Frame Top Left allows you to choose the position of the top left position of the frame. Use the arrows to proceed.

Frame/Frame Bottom Right allows you to choose the position of the bottom right position of the frame. Use the arrows to proceed.

Frame/Edge allows you to choose between an Edge around the frame, or No Edge.

• **Phase adjust**

Phase adjust is designed to move the flicker area outside the video image. This function is available only when the CD56 and the AATON 35-III are running at the same speed (both at 25 fps, for example). Use the up and down arrows for a first quick phase adjustment. And then, use the left and right arrows for a fine adjustment. To proceed, run the camera and watch the video monitor.

• **Options**

Options allows you to access to a submenu only dedicated to the AatonCode insertion.

Options/Screen allows you to choose to insert (On) or not (Off) AatonCode information, which consists of Time, Date, and Equipment number ID.

Options/Screen Y/C allows you to choose to insert (On) or not (Off) the Y/C video exit informations.

Options/Font allows you to choose the font you need for the characters to be inserted. Choose 0 for edged characters, 1 for standard characters, and 2 for bold characters.

• **Technical**

Technical allows you to access to a submenu only dedicated to the Vitc lines insertion. These lines are automatically inserted in the video image.

Technical/XTAL Adjust is a parameter adjusted in factory. Keep in mind that you should never modify it.

Technical/VITC Position allows you to choose the position of the Vitc lines. Choose between line 16 and line 24.

Technical/VITC Parity allows you to select the parity of the Vitc lines between Odd and Even. Make sure that your post-production tools run properly with the selected value.

• About the Vitc lines

In order to have meaningful information encoded in the Vitc lines, camera and video need to run at the same speed. If the video is set to run at 25 fps, then the AATON 35-III should run at 25 fps. And when the video is set to 24 fps, the AATON 35-III should run at 23.98 fps (this slight variation between these two speeds comes from some electrical imperious needs).

If the third Vitc line cannot be generated by the CD56, then a (*) appears on the screen. This might occur because of two different situations: whether the speeds of the AATON 35-III and the CD56 are different, or AatonCode has not be initialized inside the AATON 35-III.

3

THE MAGAZINE

3.1 CONCEPT

The Aaton magazine has been designed to be instantly installed or removed, and to be loaded quickly. In order to have a more compact magazine, both cores (feed and take-up) shift together during filming.

The magazine is driven magnetically from two intermediate drives connected to the camera motors; two magnetic wheels on the inner side of the camera body couple with two similar wheels on the throat of the magazine to transport the film. A magnetic drive system decreases noise and power consumption, and prevents mechanical stress during mis-loads.

The magazine handles up to 400 ft (122m) loads of 35mm film stock. 400 ft of film is a little more than 4 running minutes at 24 fps

3.2 PRESSURE PLATE SYSTEM

The magazine features two pressure plates which are located at the front of the magazine's nose. When the loaded magazine is attached to the camera, these pressure plates provide the precise stabilization of the film during exposure and transport.

3.2.1 The Gate Plate

The long plate, called the gate plate, is positioned at the camera's gate. Its main function is to stabilize the film as the claw engages the film perf between exposures. Proper tension and functioning of the gate plate contribute to reliable transport and quiet operation.

3.2.2 The Picture Plate

The striped pressure plate, called the picture plate, is positioned at the camera's aperture opening and is designed to hold the film steady at the point of exposure. Proper setting and functioning of the picture plate assures the precise focus of each image.

3.3 LOADING

3.3.1 First Step, in Daylight

Here you prepare the magazine to receive the film.

- Place the magazine on a table, its throat facing left. Unfasten the door locks by turning downward and open the door.
- You can now choose to have the footage remaining displayed (on the magazine as on the LCD control panel on the camera body) in feet or meters. The red sliding switch, accessible from the inside of the magazine, sets meters on its right, and feet on its left.
- With your thumbs, push the two spindles towards the nose of the magazine. This operation is accompanied with a loud clicking sound: don't be alarmed, this is completely normal.
- Unscrew both spindle-locks (if necessary, hold the base of the cores). The spindle-locks are easy to locate: they have the shape of a rounded rectangle.
- You can now place an empty core on the take-up spindle (the left one). Check that the core drive pin on the spindle is not caught on one of the core ribs or the roll will not seat properly. Firmly screw down the corresponding spindle-lock to secure the empty core to the spindle.

Attention! Be sure you have put the core in its correct way. To check so, imagine that you will have to fit the film in its slot. A white arrow is engraved on the base of the spindle to help you install it correctly.

- Release both sprocket pinch rollers (they have the shape of a half circle) by rotating them counter-clockwise. These rollers should be opened to let the film slide between them and the sprockets. Their half-circles face the nose of the magazine when closed, or face the chamber of the magazine if they are opened.
- Now closely look at the mechanism inside of the magazine. And memorize the following diagram and instructions.
- Then, put the magazine in a dark room or changing bag.

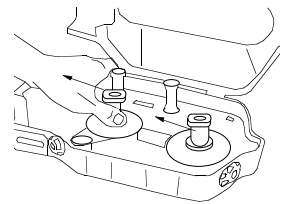
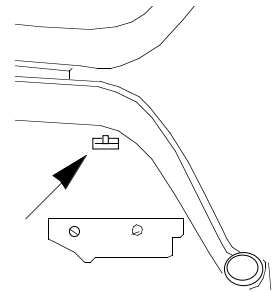

3.3.2 Loading, in the Dark

-
- Remove the film from its can and bag.
 - Place the film roll on the rear spindle. Check that the core drive pin on the spindle is not caught on one of the core ribs or the roll will not seat properly. Secure the spindle-lock.
 - Thread two feet of film, making sure it passes outside the top guiding rollers.
 - Insert the film between the pinch rollers and sprockets making sure the perforations engage with the sprocket teeth.
 - Turn the upper and lower pinch rollers clockwise, to close them.
 - Slide the film in the slot of the take-up core. Rotate this core three or four turns.
 - Check that the film is firmly attached and positioned correctly around the sprocket wheels.
 - Close the door, and fasten the door locks by turning them upward. If you cannot close the film door, it means that you have forgotten to close one or both pinch rollers.
 - The remainder of the procedure can be performed in daylight.

3.3.3 Adjusting the Loop, in daylight

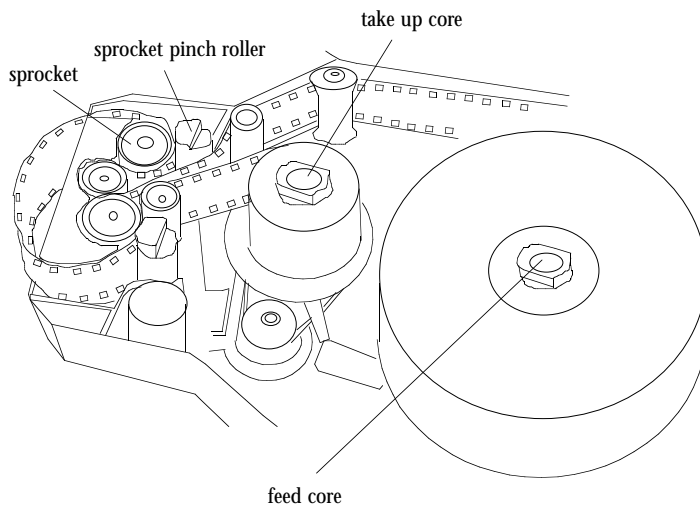

Once the door is closed, you need to adjust the loop.

- Place the magazine with its digital display facing toward you and the magazine nose being to your right. The correct loop size can be adjusted, by using the loop tool delivered with the magazine.
- If you cannot insert the tool between the mag pressure plate and

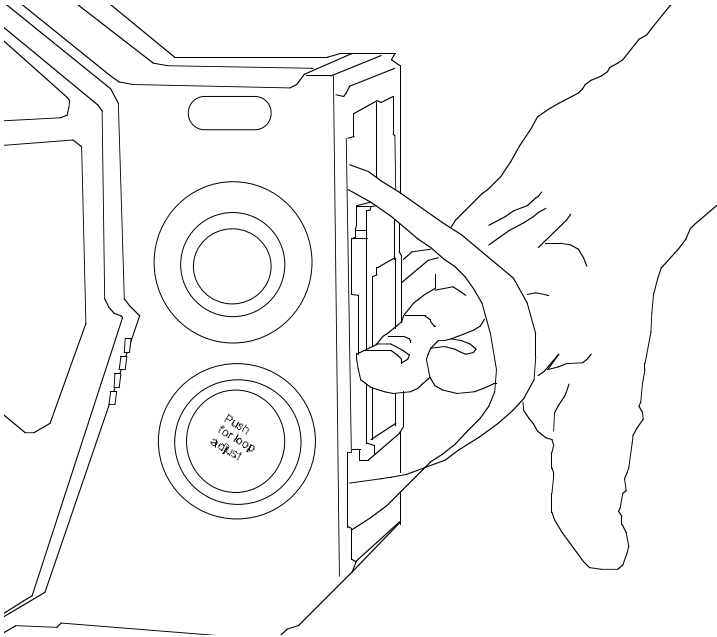

the film, you need to enlarge the loop. To do so, push the disk marked "push for loop adjust" with your right thumb while holding the film against the pressure plate with your right forefinger. Using your left hand rotate the upper magnetic wheel clockwise until the loop length allows you to insert the tool.

- If you need to reduce the loop length, simply push the disk marked "push for loop adjust" with your right thumb and rotate the upper magnetic wheel counterclockwise before installing the mag on the camera. **DO NOT FORGET** to remove any slack existing between the lower sprocket and the take-up spool. To do so, rotate the magnetic wheel situated at the left of the loop adjusting disk counterclockwise. The wheel should turn smoothly as the film winds on

the take-up core indicating that the magazine has been correctly loaded.

- You can then install the mag on the camera body.
- To engage the film, turn the camera's ON/OFF switch to test position and off again. If the loop is too short or not properly centered into the camera gate, the camera LCD display should show "LOOP". Desengage the magazine, readjust the loop length if necessary and reinstall the magazine on the camera body.

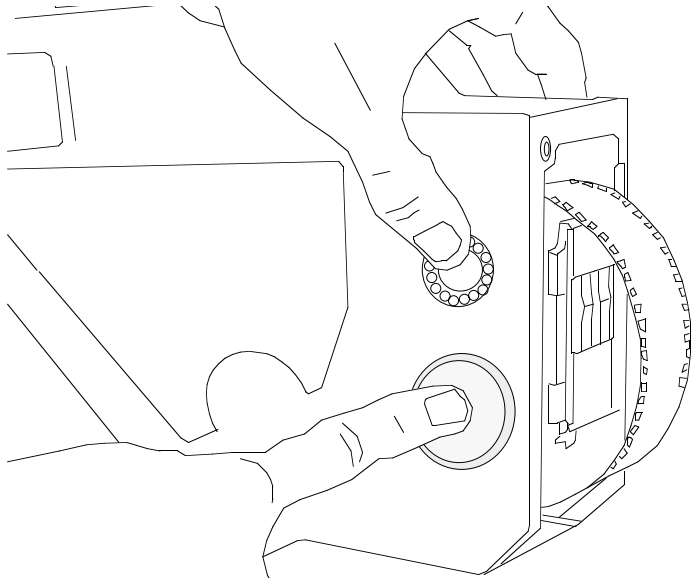

4

THE AATON SYSTEM

4.1 CAMERA CONFIGURATIONS

The AATON 35-III is designed to be easily converted between the following two accessory configurations:

4.1.1 15mm Front Rods

The most versatile and popular configuration for accessorizing the AATON 35-III, the universal 15mm screw-in front rod system can instantly accept Aaton, Arri, Chrosziel, Petroff and other manufacturers' mattebox and follow focus system.

Utilizing the front rod system allows for quick conversion from tripod to shoulder operating modes without the need for reconfiguration.

Aaton manufactures 50mm and 120mm length rods that screw directly into the front housing of the AATON 35-III under the lens port.

The 15mm front rod system is recommended when standard size lenses and accessories are to be used or when quick conversion between tripod and handheld modes is necessary.

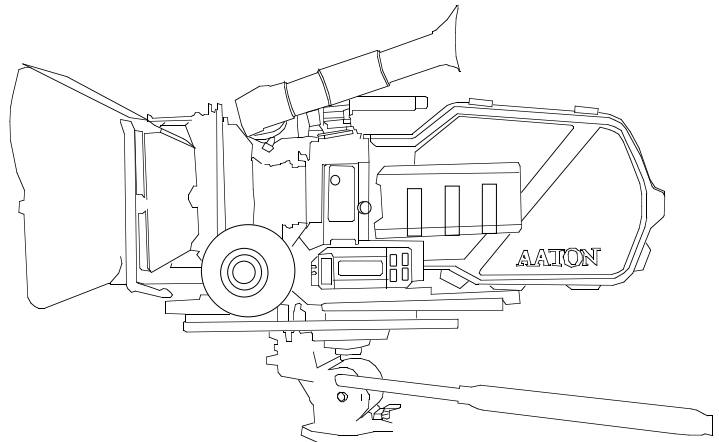

4.1.2 Sliding Bridgeplate

The AATON 35-III can also accept standard 15 and 19mm sliding bridgeplates for building the camera system for high-end studio work. The bridgeplate configuration can accept Aaton, Arri, Chrosziel and other manufacturer's mattebox, follow focus and support equipment that is designed for bridgeplate use.

Standard bridgeplates from Aaton, Arri and other manufacturers can be attached to the AATON 35-III by means of the 3/8-16 tripod receptacle on the underside of the camera.

The sliding bridgeplate system is recommended when large 35mm lenses and accessories are to be used and when the use of a geared head is necessary.

4.2 HANDGRIP

The AATON 35-III body includes a wooden handgrip, short 15mm rods, rod coupler and Lemo2 cable as standard. The handgrip which is designed to be used for comfortable handheld operation, can also be used to provide on/off control on the motor side of the camera while on the tripod.

4.2.1 Mounting the Handgrip

Screw in one 15mm short rod in each of the two receptacles on the front housing of the camera below the lens port. Slide the coupler over the two rods to the desired location and fasten the center wing nut to secure the coupler in position. Attach the handgrip to the coupler by mating the starplate on the coupler to that on the handgrip, adjusting to the desired position and fastening the T screw of the handgrip. Connect the Lemo2 cable between the handgrip and camera body to add on/off capability to the handgrip. The Lemo2 connector is located on the motor side of the camera, (between the two motors), under the Lemo8 and Lemo6 connectors.

4.2.2 Handgrip On/Off Functions

Both camera run and test functions are available from the handgrip.

While hand-holding the camera, pressing the rocker switch to the right provides camera run, pressing the switch to the left provides test. Unlike the body switch, the camera test position of the handgrip is a momentary switch. Pressing and holding the switch opens the shutter and advances the mechanism 1/2 frame. Pressing and immediately releasing this switch advances the mechanism one full frame at a 1/4 sec exposure time. This function allows the use of the handrip as a simple intervalometer.

4.2.3 Handgrip Adjustment

The handgrip rotation should be adjusted for maximum handheld operating comfort. Loosen the T screw and rotate the handgrip at the star plate until a more comfortable position is found. If a more extreme repositioning is required, whether it be for reasons of comfort or clearance in certain studio rig configurations, this can be achieved with coupler extenders, spacers and intermediate arms which utilize the star plate system for adjustment. Ask your agent for a configuration that meets your needs

4.3 TRIPOD USE

In order to use the AATON 35-III on a standard tripod, the tripod's quick release plate must be fastened to the underside of the camera body with its standard 3/8-16 screw. Make sure to use only a quick release plate screw provided by the manufacturer; non standard screws longer than 8mm (1/3") can fracture the base casting and damage the camera's electronics.

4.4 SHOULDER OPERATION

One of the most attractive features of the Aaton system has always been its comfort and ease of use in handheld situations. The AATON 35-III does not require the use of shoulder braces or

additional padding for handheld operation. The wooden handgrip is attached to the front rod coupler at a slight angle to bring the operator's elbow into his side and increase stability.

The system can be completely built off the 15mm front rods without the use of a bridgeplate to allow for quick changing from shoulder to tripod operating modes.

4.5 CARRYING HANDLE

The carrying handle of the AATON 35-III is reinforced to safely accommodate any carrying, operating or mounting operation.

4.5.1 3/8 Accessory Screw

The handle features a 3/8-16 insert to receive accessories such as french flags and lightweight monitors. Be sure not to use a 3/8 screw longer than 11mm (7/16"); longer screws can fracture the insert and damage the viewfinder's optics.

5.2 Mounting from the Carrying Handle

The 3/8 insert can also be used to build a plate to undersling the camera or to configure the rig for Steadicam low mode use. For this reason, the handle features a long flat top surface that is parallel to the bottom of the camera.

4.5.3 Tape Measure Hook

The handle is also equipped with a hideaway tape measure hook, which is positioned between the rods directly behind the 3/8 insert. To use this hook, pull it up and fasten the ring of a standard assistant's tape measure around it; the hook holds the tape measure zero point precisely at the film plane.

4.6 TRANSPORT

One often overlooked, yet vital factor in the proper functioning and longevity of your camera equipment is your transportation practices. A few good shipping habits can avert potential damage caused by careless messenger services and airport handling.

When shipping and carrying your equipment, it is always good practice to break down the package to its basic components whenever possible. Ship the body, mags and batteries unattached and individually padded. Never, under any circumstances, ship the camera with a lens attached (especially a zoom lens). Shocks transferred from the outside of a case could have disastrous effects to the ultra-critical back focus of a lens and flange focal distance of a camera if transported as one.

Make certain there is ample padding between individual components in a case and from the case's outer edges. Shipping case manufacturers suggest a minimum of 1 1/2" padding between high precision components such as the camera and lenses. 1" of padding is acceptable, however, between some of the more rugged components, such as magazines and batteries. Manufacturers also suggest to allow 2" of padding between the components and the outside of the case. Choose a case design that, not only meets your shipping and travel requirements, but allows you maximum flexibility and comfort out in the field. Check with your Aaton agent to determine the case configuration that best suits your needs.

4.7 EXTREME CONDITIONS

Certain precautions should be taken in order to achieve maximum performances when operating the AATON 35-III in extreme or adverse conditions.

4.7.1 Cold Weather

The AATON 35-III features a built-in electronic heating element

located in its base which is designed to automatically turn on when needed and maintain the claw mechanism at a temperature of 15°F. One of the cold, hard facts of cold weather shooting is the considerable reduction of battery life. Do whatever possible to conserve your batteries and always carry more than usual. Favor many small batteries, such as on-board and lithium cells (which are easier to keep warm), over large block batteries. Use a powercable so that the on-board battery could be kept in a pocket close to the warmth of your body.

When filming outdoors, use a standard or heated barney to protect the camera body from direct contact with the wind and cold. To avoid condensation inside the mechanism, electronics and lens elements, do not take the equipment indoors or expose it to sudden temperature changes. If and when the equipment must be moved inside, do so by first placing it in a sealed container and let it thaw for a few hours before opening.

Always keep your raw stock and loaded magazines above freezing temperatures at all times during a cold weather shoot.

4.7.2 Warm Weather

The keep the temperature of the camera body down, avoid having the camera exposed to direct sunlight for long periods of time by using a barney, all-weather cover, or some form of shading, like an umbrella.

Most importantly, keep raw stock and magazine in a dry cooler, or in the coolest location available.

5

CLEANING



Lens Cleaning Tips

Avoid handling lens tissues on the surfaces which will contact the lens. Oil from your hands transferred to the lens surface will make an easy cleaning job tough. Furthermore, never clean a lens element without the aid of cleaning fluid. A good number of scratches on lens surfaces are caused by poor cleaning methods.

5.1 LENS

5.1.1 Lens Elements

The front and rear surface of your lenses should be inspected regularly and always kept clean of dust particles, smudges, fingerprints, etc. First, blow off any large particles of debris using an air syringe. Lens elements should then be cleaned using lens cleaning fluid with lens tissue. Apply a few drops of cleaning fluid to a fresh lens tissue or directly to the lens. Wipe the lens in a circular fashion, starting from the center and working towards the outer edge. Finish with a fresh dry tissue. If some streaking remains, repeat the procedure until the surface is sufficiently clean.

5.1.2 Lens Exterior

The exterior of your lenses should be cleaned of dirt and adhesives as necessary. Use a multi-purpose cleaner or degreaser such as De-Solv-It applied with a Q-tip, lens tissue or cotton cloth.

5.1.3 Mounting Surface

Always inspect and keep the surfaces of your lens mount clean using alcohol or a multi-purpose cleaner with a Q-tip.

Remember, any debris found on the surface which contacts the lens seat can directly affect the back focus of your lens. Make sure the Q-tip does not leave any cotton fibers behind.

5.2 BODY

5.2.1 Exterior

Keep the external body surface clean using a cotton cloth with alcohol or a multi-purpose cleaner. use a utility brush with soft bristles to clean dirt from tight crevices.

5.2.2 Mounting Surfaces

Like the lens mount, extra care should be taken to keep the lens

port ring completely free of dirt and debris. Clean this surface, as well as the threads of the lens lock ring using alcohol or a multi-purpose cleaner applied to a Q-tip.

5.2.3 Camera Gate

The gate should be cleaned of film particles by means of a pointed wooden or plastic orange stick. The tool used should be of a soft and pliable enough material (like wood) to conform to the grooved side channels of the gate without breaking. Make sure to inspect and clean the right and left channels, the frame of the aperture opening, the lateral pressure plate, the tip of the claw, and the timecode LEDs.

Afterwards, run your fingers across the left and right rails of the gate, if your hands are clean. The oil of your finger will provide just enough lubricant for the film to pass these surfaces smoothly. Inspect the gate; if the rails are still dirty or are carrying any debris (such as the adhesive from recanned rolls of film), with a Q-tip, use a cleaning fluid that will do the job. Alcohol and lens cleaners are safe to use on the surface on the gate. Make sure the Q-tip doesn't leave any cotton threads behind.

5.3 VIEWING SYSTEM

The following components of the viewing system should be cleaned whenever dirt particles are visible through the viewfinder. Use lens fluid applied with a cotton or preferably a foam Q-tip for all areas. By cleaning the viewing system in the order described below, you will clean the more dust-prone areas first, which may help you track down most dirt particles sooner.

5.3.1 Viewing Screen

Look through the lens port at the reflection of the viewing screen in the mirror and check for visible dust particles. Remove the battery and then clear the mirror shutter so that it is rotated safely inside



Cleaning the Mirror Shutter

Do not attempt to clean the surface of the mirror shutter; any small dust particles visible from the lens port will not come into focus in your viewfinder. If large particles of dirt must be removed, do so using an air syringe. Never use canned air on this surface. If the mirror is in need of a deeper cleaning, to remove smudges or oil, take your camera to a qualified technician to be cleaned.



WARNING

Remember, the camera gate is a sensitive and high precision area directly responsible for the exact focus of the image; be careful not use hard, damaging materials (like metal) on its surface.

Under no circumstances should you perform any function within the aperture opening, lens port or near the claw with power attached to the camera. Accidentally running the camera while performing such tasks can cause serious damage to the shutter and mechanism.



Finding the Dirt...

There is a simple means of locating much of the dirt within your viewing system. Look through the viewfinder with no lens on the camera and adjust the diopter ring. If the dust particles remain in focus, they are most likely located on either side of the eyepiece. If the dust comes in and out of focus as the ring is moved, the dust is probably located on either surface of the viewing screen. Furthermore, if the dust appears to be on the same focus plane as the cross hairs of the viewing screen, it is most likely on the bottom surface on the screen and easily accessible.

the body. Remove the viewing screen. Clean both upper and lower surfaces of the screen and reinstall.

5.3.2 Eyepiece

Clean the eyepiece lens, which is the outermost element closest to your eye, by first blowing the surface with canned air, then cleaning with lens fluid and a Q-tip. Remove the eyepiece and clean the field lens, which is located on the inside of the eyepiece, in the same fashion.

5.3.3 Viewfinder

Do not install the eyepiece back right now. First, look inside the camera's eyepiece seat, and locate the two triangular lenses (called the Pechan prism). Clean these two triangular lenses using canned air or an air syringe. Then install the eyepiece back.

5.4 MAGAZINE

5.4.1 Exterior

Keep the external surface of the magazines clean by wiping down with a cotton cloth with alcohol or a mutli-purpose cleaner. When a deeper cleaning is necessary, use De-Solv-It rubbed into the mag's surface with a cotton cloth. Finish with alcohol applied with a cloth to restore its original finish.

5.4.2 Pressure Plates

The magazine pressure plates should be cleaned of dirt and film particles by means of a dust-free cotton or chamois cloth. After cleaning, run your finger across their surface for a slight lubrication.

5.4.3 Interior / Film Path

Open the door of the magazine and inspect all surfaces on which the film rides. If any film dust buildup is apparent in the sprocket or roller areas, use alcohol and a Q-tip to clean. Use a utility brush

with soft bristles to clean particles from tight crevices. Afterwards, use canned air and thoroughly blow out any remaining dust in the throat and chamber.

6

SUPER35

6.1 SUPER VS STANDARD 35MM

6.1.1 The Super35 Format

Super35 is a comeback to the cinema origins: silent cameras were exposing all the available area between perforations of the 35mm film. When came the “talkies” the picture had to be reduced to give room to the 2.54mm-wide optical sound track. Equipment manufacturers had to shift the optical axis of all their cameras and projectors by $2.54/2 = 1.27\text{mm}$. Sixty years later Super35 is coming back because it records 16/9 pictures with much less of a waste than the so called “Wide-Screen” formats. For a camera to handle both formats, it must be able to align the lens mount and the viewfinder optical axis either in the middle of the film width (Super35) or 1.27mm away (Standard35).

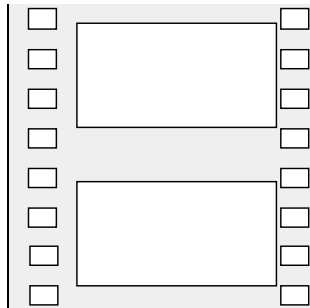

Standard 35mm

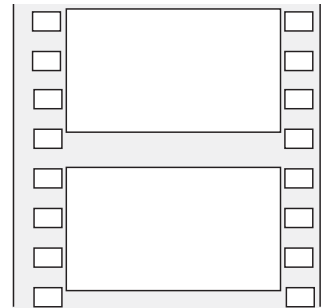

Super35

6.1.2 Why Shooting Super35 ?

If contact prints with analog sound track is not a requirement, Super35 is the unquestionable choice for maximum resolution. This format should always be selected when it comes to shoot high quality 16/9 films for video distribution only ; all telecines are able to “scan” the wider Super35 pictures with no modification at all. Super35 will be the format of choice for films treated through Kodak Cineon and Quantel Domino, or distributed with digital sound tracks only. For the time being and for normal film distribution (with analog optical sound track), this format requires an opti-

cal “reduction and axis shift” at the interpositive stage.

6.2 CAMERA CONVERSION

The 35-III camera can easily be converted from Standard35 to Super35 and back. A quick lateral sliding of the viewfinder and lens mount, that's all there is to it.

6.2.1 Lens-Mount Repositioning

The lens-mount is on a titanium seat which rests on the camera main chassis ; this seat can laterally move by 1.27mm between two stop pins. To have access to the seat, remove the two front rods and the lens locking ring, unscrew the four retaining screws of the front cap and remove the cap. The titanium lens mount seat is now accessible. Loosen (3 or 4 turns) the three screws which appear in elongated cut-outs ; push the titanium seat against the pin on the VIDEO-ASSIST SIDE to set the camera in SUPER35 (or push the titanium seat against the pin on the DISPLAY SIDE to set the camera in STANDARD35). Retighten the three screws, reinstall the front cap, the lens locking ring and the front rods.

Please note: if you are frequently swaping formats, it is advisable to install a Super35 engraved (or Standard35 engraved) front cap instead of the universal front cap delivered with the 35III camera.

These format specific caps can't be fixed on the central chassis if the titanium seat is not in the position engraved on the cap itself ; this external engraving brings peace of mind to the camera-assistant and to the prep. people.

6.2.2 Shifting the Viewfinder

The optical axis of the viewfinder need to be set to the optical center of the main taking lens. The viewfinder and the carrying handle form a block, which can easily be shifted laterally. This block is attached to the camera central chassis by 4 screws located at the base of the carrying handle. To set the viewfinder to SUPER35, loosen the 4 screws, shift the handle toward the VIDEO-ASSIST side

(until it reaches its stop), and then tighten back the screws. To set the viewfinder to STANDARD35, shift the handle toward the DISPLAY side.

6.2.3 Selecting a Viewing Screen

There is a wide choice of Standard35 viewing screens and four Super35 ones to the 1.78, 1.85, 2.35 and Scope aspect ratios. To install a new one, please read chapter II, viewing screen section. **WARNING:** when shooting Standard35 DO NOT leave the camera in the Super35 alignment, thinking that framing with a Standard35 screen will define the picture to be extracted from the wider Super35 recorded image. As far as video transfer is concerned, this practice could be acceptable because the telecine 'pan-scan' function allows to reframe the picture for the lack of 1.27mm optical center shift, but when it comes to release prints the image would be 1.27mm truncated at the projector gate level: on the left of the screen some objects would disappear and on the right some unexpected ones would show up (6% of the image width -1.27/22mm- each side).

6.2.4 Adjusting the Video Tap

The beamsplitter which diverts the viewing screen image to the video-assist CCD target is mounted on the taking lens mount titanium seat, it is thus not necessary to realign its optical axis, but the focus must to be readjusted. Please read Chapter II, video-assist section.

7

3-PERF FORMAT

7.1 CONCEPT

The only thing we know about tomorrow's high definition TV is its aspect ratio of 16/9 (1.78). This new ratio is now taking the place of the 1.85 (USA) and 1.66 (Europe) ratios. This is why it is time to re-examine the Moscow's idea (1962) of the 3-Perf format.

As a matter of fact, an image with the 1.78 ratio, with its both edges close to the 35mm film perforations, is a little higher than 3 perforations high. Why should we keep a huge amount of unused emulsion between two images (i.e. why should we keep filming in 35mm 4-perf)?

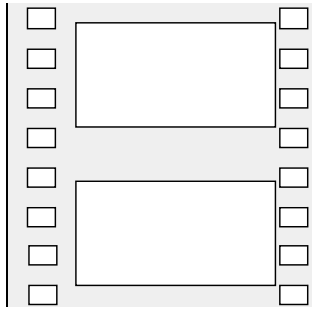

35mm standard

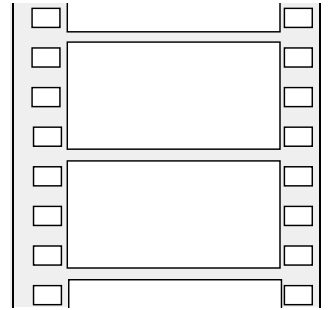

35mm 3-Perf

3-Perf presents three main advantages:

- Saves 25% on raw stock.
- Increases magazine running time (a 400' roll increase from 4 1/2 to 6 minutes).
- Allows for the camera to run quieter.

7.2 THE AATON 35-III 3-PERF CAMERA BODY

A 3-Perf camera body is available. This is a special AATON 35-III,

with the same viewing system, magazines, and lens as on a standard AATON 35-III (4-Perf). For one who already owns a AATON 35-III, it is only required to buy a 35-III 3-Perf camera body, because he can use the magazines, viewing systems, batteries, and so on which was acquired for his standard 35-III.

8

AATONCODE

8.1 CONCEPT

AatonCode, Aaton's proprietary in-camera timecode system, is recorded in the AATON 35-III on the edge of the film between the perforations in both matrix and man-readable form. As recorded in the camera, a six digit production ID, a SMPTE-compatible real time address (full date and time), an equipment ID and the running speed of the body.

TimeCode is exposed onto the film by means of seven micro-diodes, which flash rapidly to form the code as the film rolls through the gate. The intensity of the diodes is adjusted to the film's sensitivity by means of the camera's ASA selection.

The AATON 35-III can accept timecode information in both ASCII and SMPTE form, and work with all standard timecode devices. Because the same time address is running in both the camera and the sound recorder, a slate is no longer needed for syncing purposes; synchronization becomes fully automatic during the film/tape transfer or later post-production stages.

An Aaton device called Keylink, which consist of CCD reader heads and a PC, and which is owned by the telecine house, is designed to read Keycode and AatonCode off the film during transfer and correlate this to the continuous video timecode and all other transfer data entry for storage on its hard drive. Keylink can also ingest scene/take information and notes from the set recorded by means of Aaton's ScriptLink software.

The facility can then supply all correlated information in VITC (vertical interval timecode) and/or burn-in windows on the transferred tape, and also on floppy disk for direct use with non linear editing systems, audio workstations and logging programs.

8.2 THE INTERNAL CLOCK

The AATON 35-III contains an internal clock designed to be initialized from an outside source and keep accurate time (within a half a

frame) for 8 hours.

The camera is equipped with an instantly charged supercapacitor buffer that is designed to keep time between battery changes. Keep in mind that a battery which is too low to run the camera has enough energy to drive internal clock for hours. Get into the habit of leaving an exhausted battery on-board the camera until you have a fresh battery close by. The supercapacitor allows a full minute for battery replacement before timecode is lost.

8.3 ORIGINC^{PLUS} MASTERCLOCK

For the most efficient and foolproof means of working with Aaton-Code, it is highly recommended that an Aaton device called OriginC^{plus} is used. OriginC^{plus} can be quickly programmed with a production ID, full date and time of day, then initialize timecode devices in either ASCII or SMPTE form. OriginC^{plus} is TCXO-controlled and will run for 150 hours with an internal 9V lithium cell; it is designed to be left on during the shoot day and used as a comparator to monitor timecode drift between devices.

OriginC^{plus} can also be used as a SMPTE generator to supply accurate timecode for slates and inserters, or to record timecode on one audio channel of a non timecode audio recorder.

8.4 INITIALIZING AATONCODE IN THE CAMERA

There are two ways in which AatonCode can be initialized in the AATON 35-III camera. The preferred method is by means of the OriginC^{plus}, which inputs timecode in ASCII form. It is also possible for the camera to receive information in SMPTE from directly from a SMPTE timecode device such as an TC audio recorder. Both methods are detailed below.

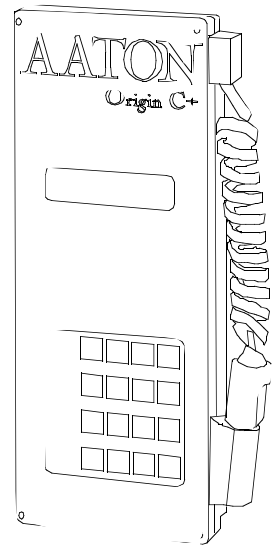

8.4.1 Using the OriginCplus - Recommended Method

- Program the OriginCplus by inputting Prod ID, accurate date and time of day. Press the # key to scroll through each field; after all fields are set as desired, press * to start the clock.
- Make sure the camera has a battery attached.
- Plug the Lemo5 cable of the OriginCplus into the Lemo5 chassis mount on the base of the camera.
- Press * on the OriginCplus to send the timecode information. The OriginCplus will display Good OO.O after the timecode has been accepted in the camera. The control panel of the AATON 35-III will display hours/minutes/seconds when the button marked Time is pressed. Toggling this button will also display year/month/day, then the production ID, then the equipment #.
- Make sure to adjust the ASA selection to the exposure index of the film stock being used.
- Disconnect the OriginCplus from the body and proceed to the next device.

8.4.2 Using an External SMPTE Device

- Make sure the AATON 35-III has a battery attached and is not running.
- Choose the SMPTE timecode device that will be supplying the timecode (such as a Fostex PD2 or a Nagra IVS-TC). Set the time of day and date, and set its clock to free run mode.
- Connect a cable from the SMPTE output of the timecode device to the Lemo5 chassis mount on the base of the camera.
- Set the on/off switch on the camera to run or test position, then off again; this will send the timecode information to the camera body. The AATON 35-III will display hours/minutes/seconds when the button marked Time is pressed. Toggling this button will also display year/month/day and the equipment #. No production ID will be recorded.
- Disconnect the cable from the body and proceed to the next device.

8.5 MONITORING AND MAINTAINING

AATONCODE

After initialization, the OriginCplus should be left on during production to act as a visual reference and for quick drift monitoring. Once timecode has been initialized into the camera(s) and sound recorder, accurate time will be individually maintained in each machine for 7 hours. It is suggested, however, that new timecode be re-initialized after 4 hours or so as a precautionary measure. Get into the habit of using the OriginCplus to monitor timecode drift in each device when possible; every 2-3 hours or so is recommended.

8.5.1 Monitoring AatonCode with OriginCplus

Assuming that the OriginCplus has been left on during the production, follow the simple procedure below to monitor drift in the camera.

- Plug the Lemo5 cable of the OriginCplus into the Lemo5 chassis mount at the base of the camera.
- Press * to monitor AatonCode drift. OriginCplus will compare its own timecode to that of the AATON 35-III. OriginCplus will display Good, fair, bad or diff-time (different time) followed by the amount of drift in tenth of frame.
- Follow the same procedure for each camera or sound recorder on the set running AatonCode. When initializing or monitoring timecode in a SMPTE device, press *0 on the OriginCplus.

8.5.2 Maintaining AatonCode without OriginCplus

If the OriginCplus has not been used and timecode has been set directly from the TC audio recorder, there is no way to monitor timecode drift between the two devices. In this case, it is recommended to simply re-jam the camera every 2 or 3 hours.

Make sure that the camera on/off is switched to run or test position for it to accept the newly fed code.

8.6 GMT1 SMPTE GENERATOR

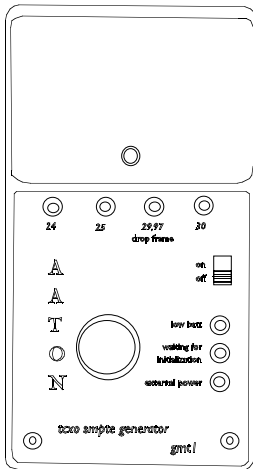

Because more and more cineasts are using sound recorders not specifically designed for cinema, which means with no integrated timecode, Aaton needed to modify its *OriginCplus*: now, *OriginCplus* is able to serve as a SMPTE generator, which you can connect to any sound recorder.

But *OriginCplus* may be too big and too powerful for such an usage. So Aaton decided to build the GMT1, a mini SMPTE generator also designed to provide a timecode track for any sound recorder. The GMT1 is smaller than the *OriginCplus*, and can work continuously for 150 hours with just a standard 9V battery. Its timecode informations (time and date) can be initialized with any SMPTE generator such as *OriginCplus*.

To choose the SMPTE frame rate you need (according to the speed of your camera), remove the battery cover and turn the small white cross, beside the 9V battery, with a screwdriver. You can choose between 24, 25, 29.97 and 30 fps. The selected frame rate LED will flash every second.

You can also use the GMT1 as an *OriginCplus* supplier: if one day, by mistake, you have forgotten to take your *OriginCplus* with you, then use the GMT1 to initialize timecode in your camera. The GMT1, with no timecode initialized inside, is still able to generate a SMPTE code, starting at 1h 00mn 00s.

8.7 THE CAMERA ASSISTANT'S DUTIES

Although timecode-related practices on the set are very straightforward and uncomplicated, there are a few duties which should be handled by a camera assistant as part of his/her routine.

8.7.1 Checking the Diodes

In order to inspect and clean the gate between magazine rolls, the camera must be set to test position. Not only will test position rotate the shutter 180°, but the seven timecode LEDs in the gate will illuminate in a three/four sequence. Use this pattern to occasionally

check that all diodes are operational and evenly illuminated. As part of the normal gate cleaning procedure, clean this area with a Q-tip moisten with lens cleaning fluid to assure that no dust particles cover the LED array.

The seven diodes will illuminate in test position whether or not timecode is running in the camera.

8.7.2 Setting the ASA

When changing magazines, make sure the ASA/ISO setting of the camera matches the film stock being used.

9

TECHNICAL SPECIFICATIONS

9.1 TECHNICAL SPECIFICATIONS

Weight 7kg (16 lbs) with 400' load and on-board battery.

Power Brushless, high efficiency tri-phase motor; 1.4 amp consumption with film at 25°C (77°F) under 12V power supply (10-15V).

Temperature Range -10°C (14°F) to +40°C (104°F)

Noise Level 4-Perf: 30 / 33 dB. 3-Perf: 27 / 30 dB

Frame Rate Sync speeds: 24, 25, 29.97, 30 fps. Built-in var crystal control to 2 to 40 fps in 0.001 increments.

Steadiness Co-planar claw movement for lateral and vertical steadiness to 1/2000th of image dimension.

Viewing System Interchangeable screens: 1.37, 1.66, 1.78, 1.85 aspect ratios.

Camera Mounts Interchangeable hard front: ArriPL, Panavision, Nikon.

Shutter Reflex mirror, user-convertible on option; 180° for 24 fps under 60 Hz lighting, 172.8° for 24 fps under 50 Hz, 150° for 25 fps under 60 Hz, 144° for NTSC monitor.

35 / Super 35 Quick centering of lens axis for either format.

Time Code AatonCode man-readable figures and rugged SMPTE matrixes. 1/2 frame accuracy over 8 hours.

Accessory Inputs Amph9 (video sync), Lemo6 (power zoom), Lemo8 (speed controllers de vitesse), Lemo5 (SMPTE and RS232).

Video Assist Black & White - low power, high sensitivity, integrated CCD assist with manual iris. PAL or NTSC formats.

Color - high sensitivity, flicker-free, integrated CCD assist with timecode windows and Vitc insertion. PAL or NTSC formats.

Magazine Instant, 400', reading in feet or meters.

LCD Display Speed selection, remaining footage, ISO selection, battery voltage, full AatonCode readout via a single rotating jog.

Operator Warning Speed discrepancy, misloading, low battery indicator.

Camera Shut-off Automatic at end of roll.

9.2 CONNECTOR - PIN ATTRIBUTIONS

Type	Fonctions	Diagram	Localisation	Pin Attributions
<i>Lemo2</i>	On/Off/Test		<i>Between the two motors. Looking down.</i>	1 Ground 2 Start
<i>Lemo5</i>	TimeCode Interface		<i>Under jog wheel.</i>	1 Ground 2 Smpte In 3 ASCII In/Out 4 et 5l <i>Not used</i>
<i>Lemo6</i>	Power Zoom		<i>Above the right motor.</i>	1 -Batt 4 +Batt 6 Start 2, 3 & 5 <i>Not used</i>
<i>Lemo8</i>	Speed Controllers		<i>Above and to the right of the left motor.</i>	1 -Batt 2 TV Sync 3 ASCII In/Out 4 +Batt 5 100 PFF Out 6 Start 7 100 PFF In 8 Ground
<i>Amph9</i>	Video Sync		<i>Above the left motor.</i>	1 -Batt 2 TV Sync 3 2400 Hz 4 ASCII In/Out 5 +Batt 6 -Batt 7 Strobe 8 Start 9 +Batt
<i>XLR4</i>	Power In		<i>Above the jog wheel.</i>	1 -Batt 4 +Batt 2 et 3 <i>Not used</i>

● pin ○ socket

1.85

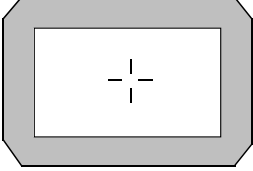

ACAD + TVTRANS + TV safe +1.66

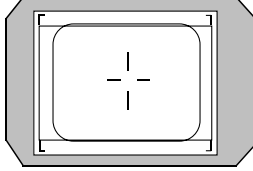

1.85 SUPER35

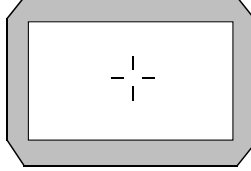

1.66

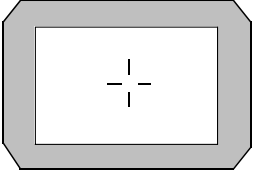

SCOPE 2.35

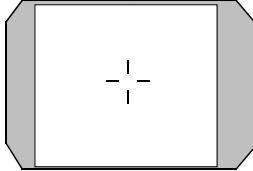

1.37 + 1.66 & 1.85 markings

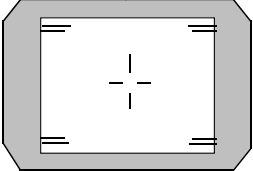

1.85 SUPER35

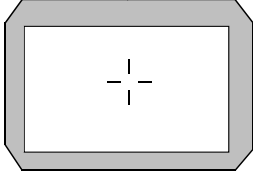

ACAD+TVTRANS+ TV safe + 1.85

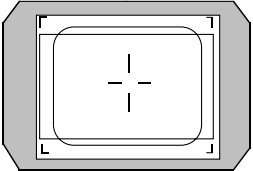

1.85 + SCOPE SUPER35

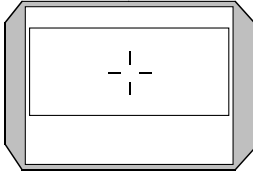

ACAD+TVTRANS+ TV safe

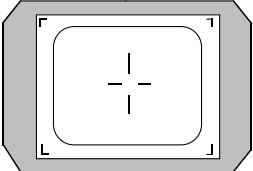

2.35 + SUPER35

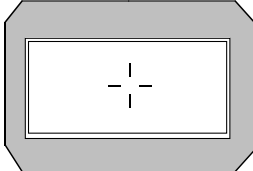

10

WORLDWIDE SUPPORT

Australia

LEMAC FILM

277 Highett Street

Victoria 3121 RICHMOND

Contact: John Bowring

Tel : 61 39 429 8588

Fax : 61 39 428 3336

Belgium

COLOR BY DEJONGHE

Diskmuidekaai 4

B 8500 KORTRIJE

Contact: Dirk Dejonghe

Tel : 32 5635 0710

Fax : 32 5635 0780

Brazil

HAGA DE

Rua Sergipe 475 cj. 711

Cep 01234-001 SAO PAULO

Contact: Hugo Kovenski

Tel : 55 11 258 5752

Fax : 55 11 258 5752

Canada

Cineasst

332 Dupont street

M5R 1V9 Toronto Ontario

Contact: Pierre Careau

Tel : 416 975 2565

Fax : 416 975 0895

Denmark

ZIMMERMANNFILM & VIDEO TEKNIK

H.C. Orstedsvej 11 B

DK-1879 Frederiksberg C

Contact: Peter Zimmermann

Tel : 45 3325 8525

Fax : 45 3325 8523

France

AATON S.A.

2 rue de la Paix BP 3002

38001 Grenoble Cedex

Contact: Danys Bruyère

Tel : 33 (0) 4 7642 9550

Fax : 33 (0) 4 7651 3491

Germany

DEDO WEIGERT FILM

Karl-Weinmair Strasse 10

80807 Munich 40

Contact: Victoria Johnson

Tel : 49 89 356 1601

Fax : 49 89 356 6086

Great Britain

ICE FILM EQUIPMENT

156 Caledonian Road

N1 9UU London

Contact: Peter Bryant

Tel : 44 171 278 0908

Fax : 44 171 278 4552

Greece

CHASSAPIS

Olymbou St 55

152 34 HALANDRI ATHEN

Contact: Stravos Chassapis

Tel : 30 1 682 1237

Fax : 30 1 684 6584

Holland

HOLLAND EQUIPMENT

Van Marwijk Kooystraat 14

1096 BR Amsterdam

Contact: Nico Van Den Boogard

Tel : 31 20 694 35 75

Fax : 31 20 668 53 81

Japan

SUZUKI ENTERPRISE

Dai Ichi Nichiya Bldg 2F

Hatagaya Shibuya-Ku

151 Tokyo

Contact: Sadaaki Suzuki

Tel : 81 353 50 8235

Fax : 81 353 50 8237

Malaysia

TRANS ASIAN & AMERICAN FILMS & CINEMA

7, Tingkat Taman Ipoh - 10 Tel : 605 545 7113

31400 Ipoh, Perak Fax : 605 547 7873

Contact: Alexander Sange

Portugal

ANIMATOGRAFO

Rua da Rosa 252 Tel : 351 1347 4593

1250 LISBOA Fax : 351 1347 3252

Contact: Antonio Cunha Telles

Spain

EPC

Nieremberg 29 Tel : 34 1 519 4221

28002 MADRID Fax : 34 1 519 2198

Contact: Oscar Perez

Sweden

RE FILM SERVICE AB

Strindbergsgatan 58 Tel : 46 8 662 25 35

115 53 STOCKHOLM Fax : 46 8 662 25 03

Contact: Lars Wedberg

Switzerland

GH team

15 Chemin de la Rochette Tel : 41 22 733 06 38

CH-1202 Geneva Fax : 41 22 734 44 89

Contact: Georges Hofer

USA

AbelCine Tech / LA

4110 West Magnolia Blvd Tel : 1 (818) 972 9078

Burbank, CA 91505 Fax : 1 (818) 972 2673

Contact: Rich Abel

AbelCine Tech / NY

66 Willow Avenue

NY 10305 Staten Island

Contact: Peter Abel

Tel : 1 718 273 8108

Fax : 1 718 273 8137

11

INDEX

3-Perf 2.6, 7, 7.1, 7.2, 9.1
AatonCode 1.2, 1.5, 2.7.2, 2.9.3, 2.9.4, 2.11.3, 8, 8.1, 8.3, 8.4, 8.5, 8.5.1, 8.5.2, 9.1
Amph9 1.4, 2.8.3, 2.11.2, 9.1, 9.2
Aperture opening 1.2, 2.2.8, 2.9.3, 3.2.2, 5.2.3
ArriPL 2.1.1.1, 9.1
ASA 1.2, 1.3, 2.9.4, 8.1, 8.4.1, 8.7.2
Battery 1.2, 1.3, 1.4, 2.3.2, 2.7, 2.7.1, 2.7.2, 2.7.3, 2.9.5, 2.9.12, 2.9.13, 2.10.4, 8.2, 8.4.1, 8.4.2, 8.6, 9.1
Carrying handle 1.3, 2.2.4, 2.2.5, 4.5, 4.5.2, 6.2.2
Claw 1.4, 2.3.1, 2.4, 2.4.1, 3.2.1, 4.7.1, 5.2.3, 9.1
Cleaning 2.2.8, 5, 8.7.1
Cold weather 4.7.1
Diopter set ring 1.1, 2.2.4
Empty 1.5, 3.3.1
Eyepiece 1.1, 1.4, 2.2.1, 2.2.2, 2.2.4, 2.2.5, 5.3.2, 5.3.3
Feet or meters 3.3.1, 9.1
Flicker 2.1.1, 2.11.3
Footage 1.2, 1.5, 2.9.2, 2.9.10, 2.9.11, 2.9.13, 3.3.1, 9.1
Friction adjusting ring 1.1, 2.2.3
Front rods 1.1, 4.11, 4.4
Gate plate 3.2.1
GMT1 8.6
Intervalometer 2.8.4, 4.2.3
Jog wheel 1.2, 2.8.1, 2.9, 2.9.4, 2.9.7, 9.2
Keycode 2.11, 8.1
Keylink 8.1
LCD Control Panel 1.2, 1.5, 2.8.1, 2.8.3, 2.9, 2.9.1, 2.9.3, 2.9.12
LEDs 5.2.3, 8.7.1
Lemo2 1.4, 2.8.3, 4.2, 4.2.1, 9.2
Lemo5 1.2, 2.9.3, 8.4.1, 8.4.2, 8.5.1
Lemo6 1.4, 2.8.3, 2.11.2, 4.2.1, 9.2
Lemo8 1.4, 2.8.3, 4.2.1
Lens 1.1, 2.1, 2.11, 2.12, 2.2.4, 2.2.9, 2.5.3, 4.12, 4.6, 5.1, 5.12, 6.1, 6.2.3, 9.1
Lo Batt 1.5, 2.10.4
Lo Spd 2.10.5
Loading the magazine 3.3, 3.3.2
Loop 1.5, 2.4.1, 2.8.3, 3.3.3
Mag release lever 1.4
Magazine 1.2, 1.3, 1.4, 1.5, 2.6, 2.6.1, 2.6.2, 2.9.6, 2.11.3, 3, 4.6, 4.7.1, 5.4, 8.7.2, 9.1
Magnetic wheel 1.2, 3.1, 3.3.3
Meters or feet 3.3.1, 9.1
Mirror Shutter 1.2, 2.2.8, 2.3, 5.3.1
Nikon 2.11, 2.5.5, 9.1
Noise 2.4.1, 2.8.2, 3.1, 3.3.1, 9.1
OriginCplus 2.9.3, 8.3, 8.4.1, 8.5, 8.5.1, 8.5.2, 8.6
Panavision 2.1.1.1, 2.5.5, 9.1
Picture plate 3.2.2
Pitch 1.2, 2.4.1
Power 2.7, 2.7.3, 2.8, 2.9.5, 2.11.2, 9.1
Pressure Plates 3.2, 5.4.2
Pulldown claw 1.4, 2.3.1, 2.4, 2.4.1, 3.2.1, 4.7.1, 5.2.3, 9.1
Run/Test switch 1.3, 1.4, 2.8.3, 2.9.4
Scratch 1.5
Set Mode 1.5, 2.9.2
Show Mode 1.5, 2.9.2
Spacer 2.5.2, 2.5.3, 4.2.3
Speed 1.5, 2.8.1, 2.8.2, 2.9.1, 2.9.7, 2.9.8, 2.9.9, 2.10.5, 2.11.3, 8.1, 9.1
Super35 6, 9.3
Tape measure stud 4.5.3
Technical Specifications, 9.1
Timecode 2.9.3, 2.9.4, 5.23, 8
Transport 3.1, 3.2, 4.6
Unadjust 1.5, 2.9.14
Video assist 2.11, 6.2.4, 9.1
Viewfinder 1.1, 2.2.1, 2.2.3, 2.2.4, 2.10, 5.3, 5.3.2, 6.2.2
Viewing screen 1.3, 2.2.7, 2.2.8, 2.2.9, 2.5.4, 2.11.3, 5.3.1, 6.2.1, 6.2.2, 6.2.3
Vitc lines 2.11.1, 8.1, 9.1
Warnings 1.5, 2.9.14, 5.2.3, 9.1
Weight 2.2.3, 9.1
Wooden Handgrip 1.1, 2.8.3, 4.2, 4.4
Worldwide Support 10
XLR4 1.2, 2.7.2, 2.7.3, 9.2

